

GA-3600/W24 SERIES

ALUMINUM-WHEEL TURNING CENTERS

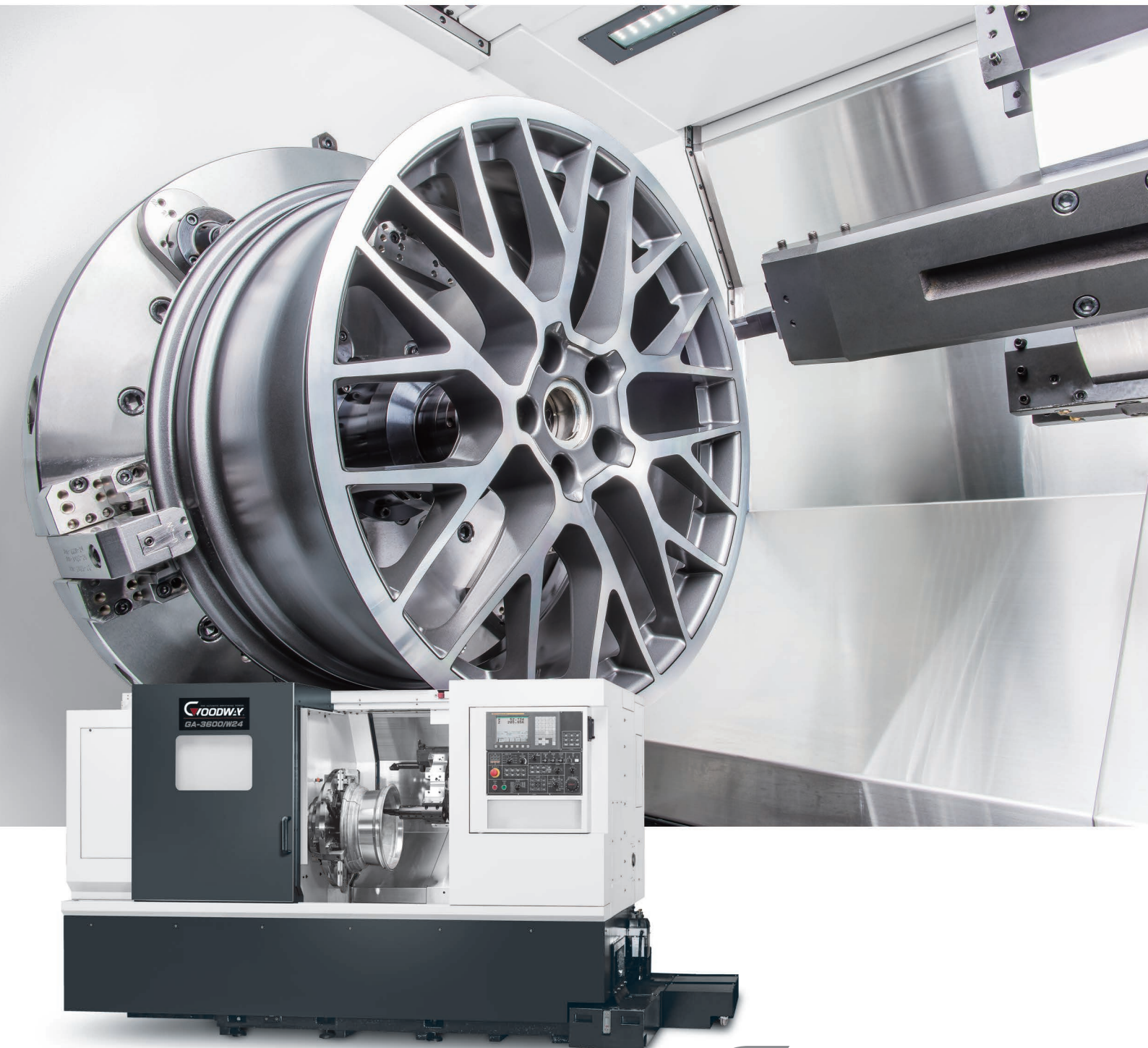

THE ULTIMATE MACHINING POWER
WOODWAY

HIGH PERFORMANCE ALUMINUM-WHEEL TURNING CENTER

Packed with industry leading technology and top quality components, GOODWAY GA-3600/W24 combines strong constructions, customizable integrated interface for chucks, and efficient chip disposal capabilities to bring you the top choice of aluminum wheel turning center in the market. With the advantages of the load / unload feature, GA-3600/W24 series can rapidly replace cam arms and ring locators to complete 1st and 2nd operations all at once. You can combine 2 sets GA-3600/W24 machines with a machining center and robot arm to form a high performance production line that is sure to meet your turning applications for aluminum wheels of today and tomorrow.

- ▶ Extremely powerful high-torque spindles deliver 2.5 ~ 4 times the torque output of standard spindles.
- ▶ Extra large X and Z-axis servo motors provide rapid acceleration and deceleration and powerful thrust. Max. feed rate can reach up to 20 m/min and 24 m/min.
- ▶ In order to endure the machine's high outputs with durability, heavy-duty roller bearings are used to support the spindles and axes guide ways are of super-rigid box ways design.



Automatic Aluminum Wheels Production Line

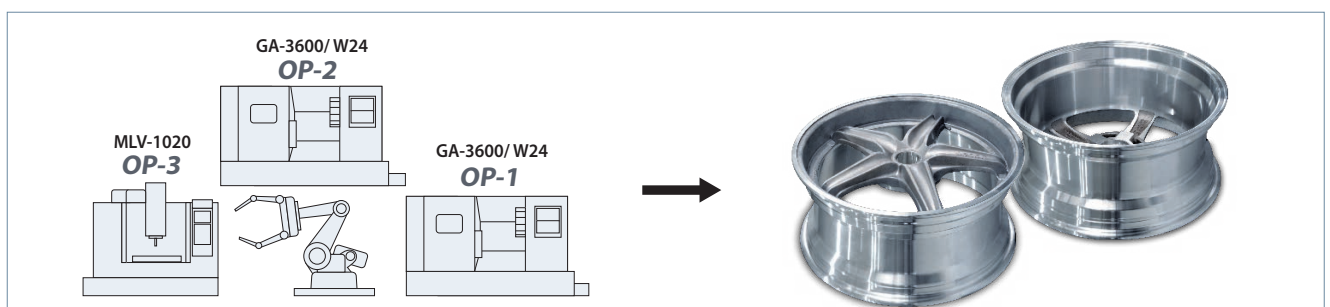

- ▶ Goodway production line for aluminum wheels incl. 2 sets GA-3600/W24, a machining center with robot arm and automatic accuracy detection system. From loading, front and rear turning, drilling, tapping, unloading and accuracy test can be finish in one complete production line. It greatly reduce manpower and time for fixture adjustment to form a high efficiency of aluminum wheels production.

(Goodway provides customized service with best solution for production line.)



OP1 ▶ Rough cutting on a sloping edge, Fine Boring in the center, Fine cutting on a sloping edge, Rough cutting on the bottom of a wheel, Fine cutting on the bottom of a wheel.



OP2 ▶ Rough cutting on the bottom of a wheel, Fine cutting on the bottom of a wheel.

O.D. Fine Turning

Tools	Turning Diameter (mm)	Cutting Length (mm)	Cutting Speed (m/min)	Feed Rate (mm/rev)	Spindle load	Single Side (mm)
TMS HHG 630	495.0	90.0	600	0.50	53%	4

Surface Roughness

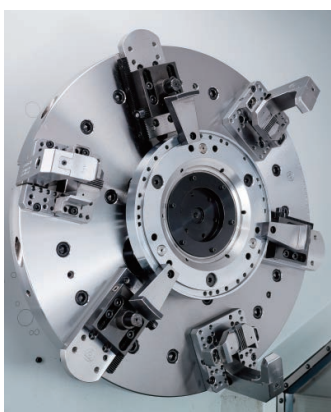
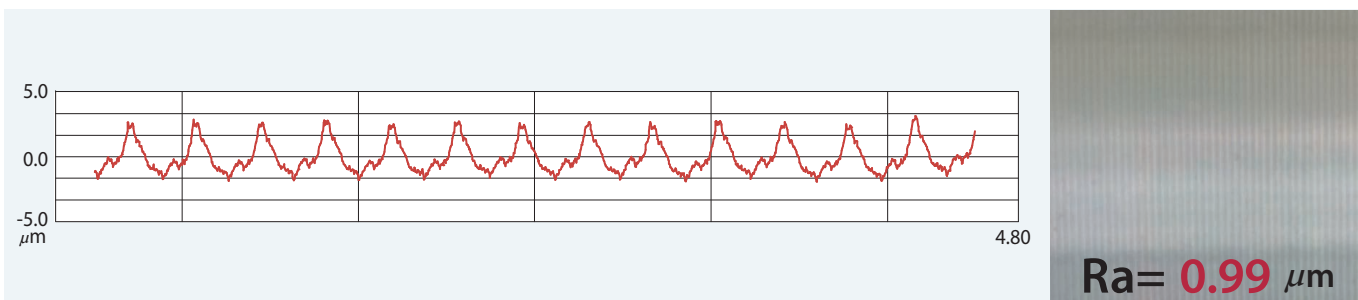

Specialized Aluminum Wheel Finger Chuck

- ▶ A module design chuck enables processing different sizes of aluminum wheels by simply replacing the cam arm and adjusting the ring locator, thus saving more acquisition costs.
- ▶ The finger chuck can easily clamp materials with burrs and the standard positioning disc provides accuracy which increases loading efficiency.

(Hydraulic chuck is optional based on customer's requirements. Goodway provides profound customized service.)

SUPER HEAVY-DUTY CONSTRUCTION

- ▶ Built to endure years and years of rigorous high production turning, the heavily ribbed, one-piece thermally balanced bed and casting components are of FC35-MEEHANITE casting (industry standard is FC25~30). FC35 grade cast iron is capable of withstanding much greater stress without deforming and provides maximum vibration damping, which result in a machine that will outlast and outperform the competition.
- ▶ The low center of gravity heavy-duty bed provides a super foundation for the headstock and turret. With 30° slant wedge saddle design, chips can be easily taken away from the working area.
- ▶ All spindle and servo motors, including drives, are FANUC α i series components to ensure peak machining performance and accuracy.

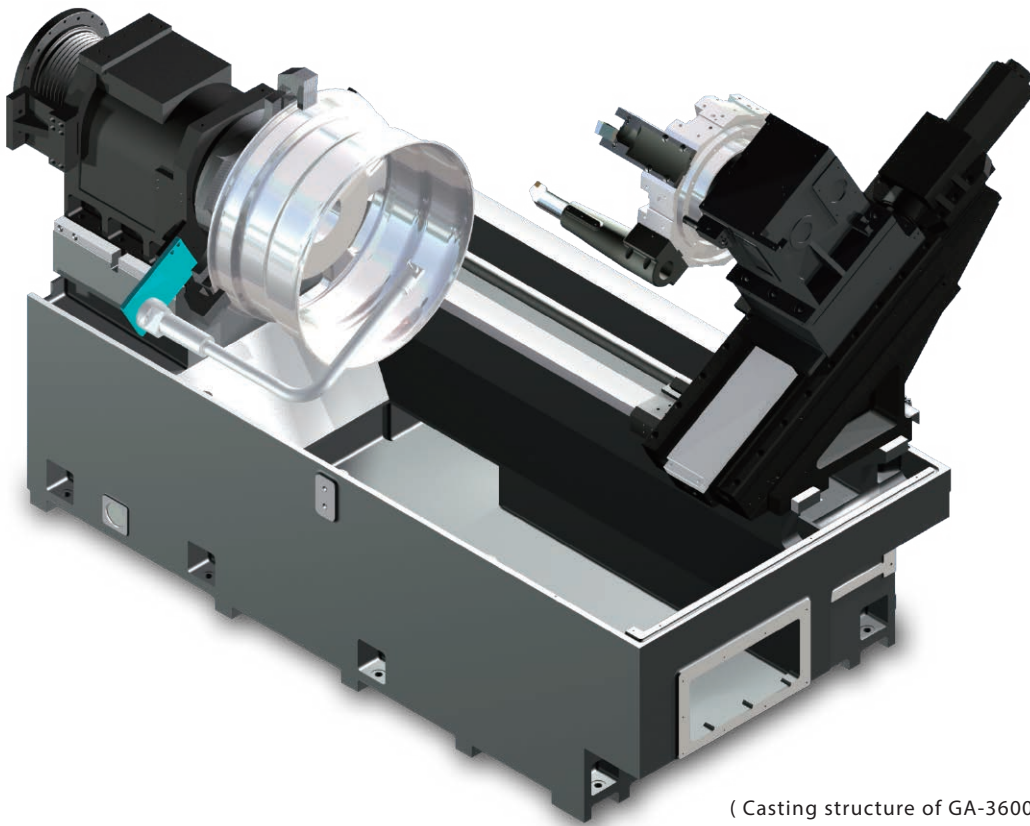

(Casting structure of GA-3600/W24 model shown)

- ▶ Extra wide, hardened and precision ground box ways are widely spaced, and directly cast on to the machine bed and saddle for maximum strength and precision.

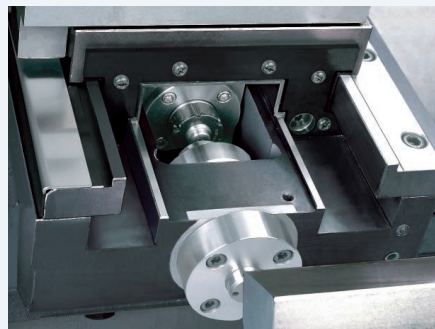
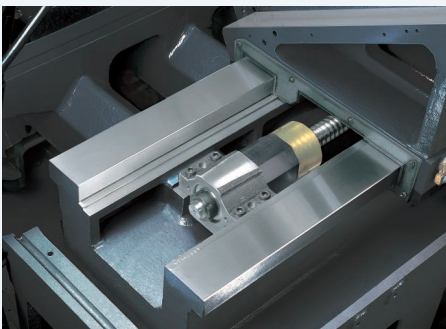

- ▶ C3 class hardened and precision ground ball screws ensure the highest accuracy and durability possible. Plus, pretension on all axes minimizes thermal distortion.

ULTIMATE TURNING POWER

- ▶ 3,000 rpm high torque spindle with 45 kW (15 min.) output FANUC α 30 / 7000*i* spindle motor provides max. torque 577 Nm under 745 rpm which meet the requirement of heavy cutting.
- ▶ P4 grade (Class 7) super-high precision bearings are directly assembled for maximum level of support and precision. Bearing configuration is designed for super heavy-duty cutting with ultra-smooth performance and long term durability with a higher level of accuracy.

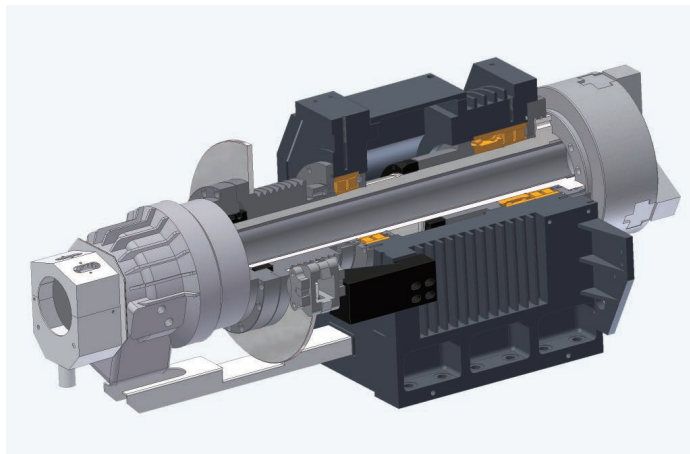

Spindle Output

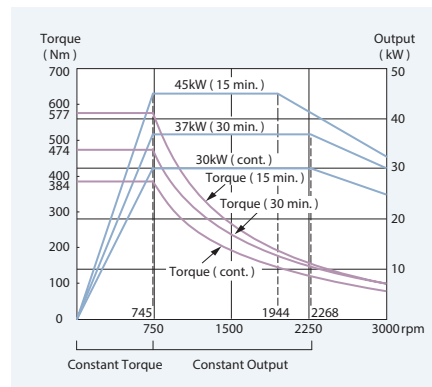

- ▶ Ø250 mm diameter super high precision curvic couplings accurately position the turret disk and 4,400 Kg of clamping force ensures abundant turret rigidity for all cutting conditions.
- ▶ The heavy-duty servo indexing turret achieves 0.3 second indexing times for adjacent stations and 0.5 second for stations at the opposite end of the disk. Index movements are single step, without pauses, no matter how many stations are skipped.

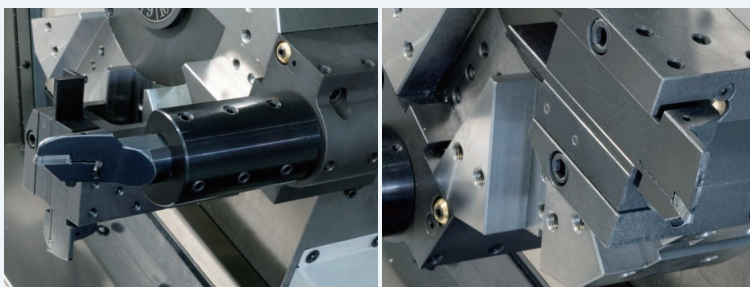
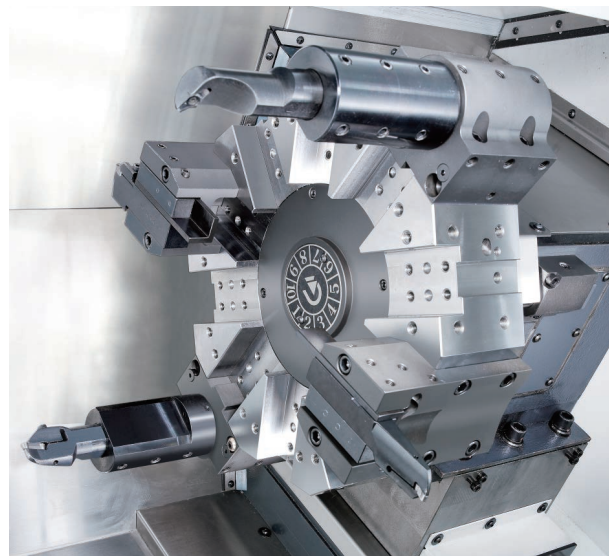

- ▶ The Goodway aluminum-wheel tool holder is reinforced with specialized structural design to eliminate vibration and avoid tool overhang. This provides great precision accuracy on workpiece surface and can significantly extended tool life

GENERAL DIMENSION

Interference Diagram

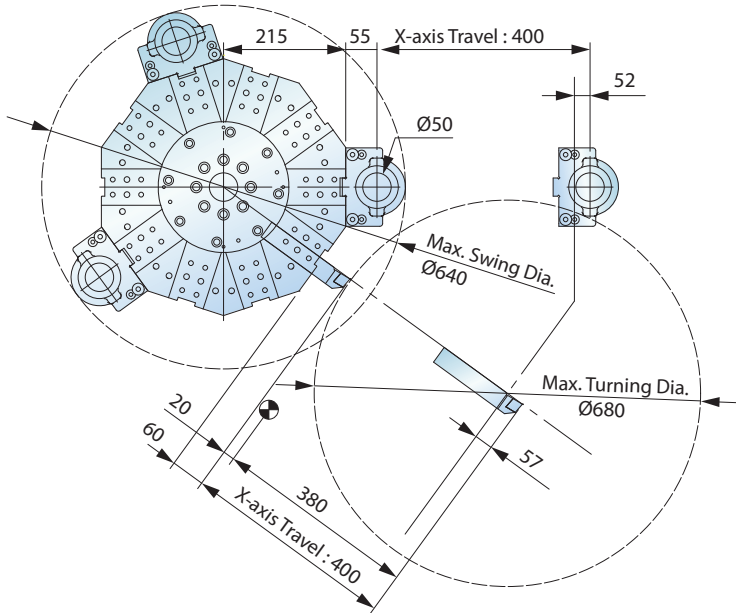

Work Range

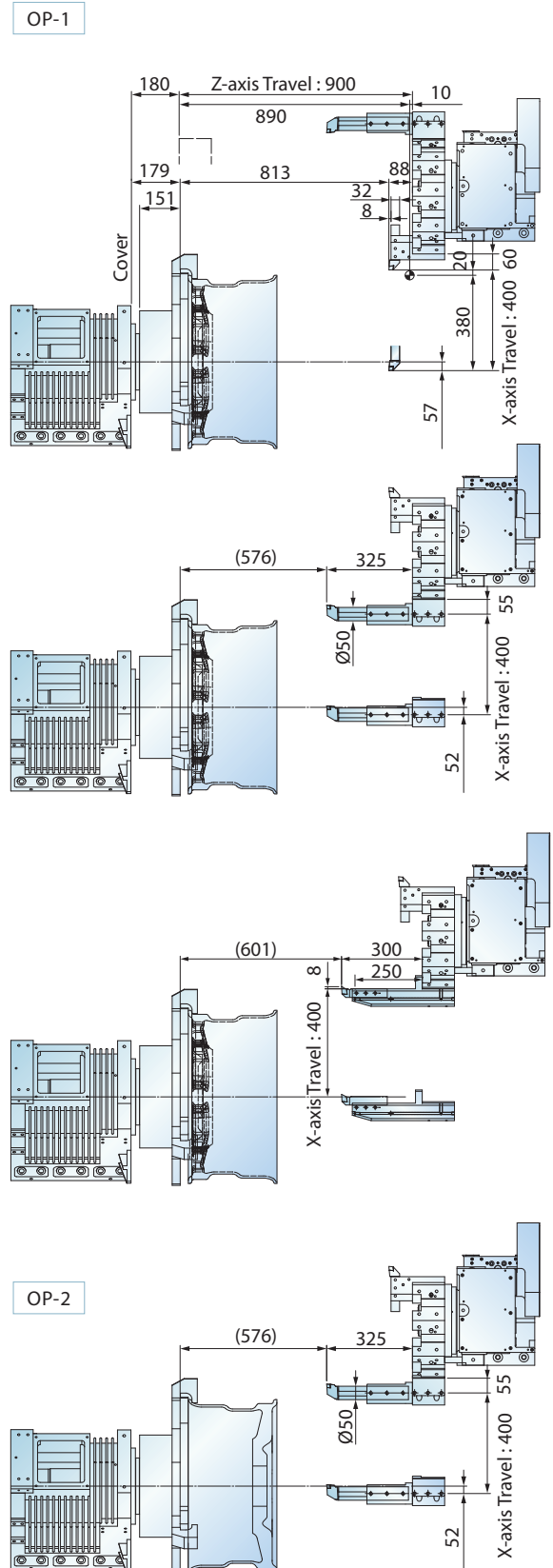

Tooling System

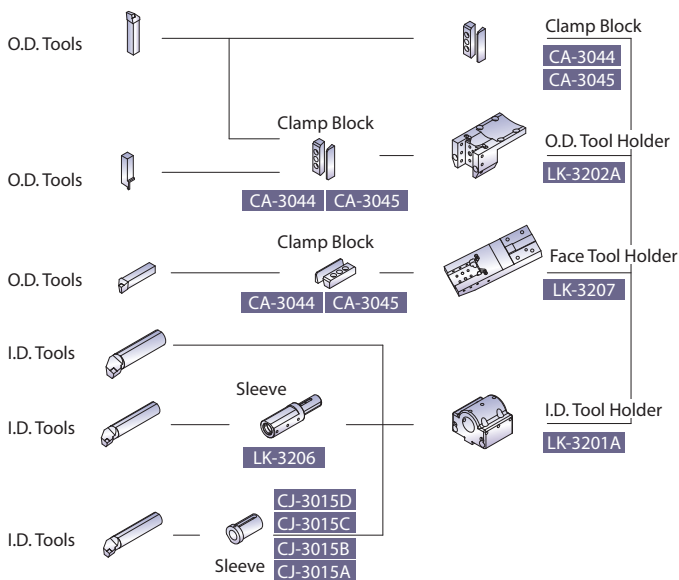

STANDARD & OPTIONAL FEATURES

S : Standard O : Option
 - : Not Available C : Contact GOODWAY

GA-360 / M2A

SPINDLE		
Main spindle motor configuration	Single-speed	S
Rigid tapping & spindle orientation		S
WORK HOLDING		
Hydraulic hollow 3-jaw chuck	15"	S
Hard jaws	1 set	O
Soft jaws	1 set	S
Special work holding chuck		C
Foot switch for chuck operation	Single	S
Two-stage programmable pressure	Chuck clamping	O
TURRET		
10-station turret		S
Tool holder & sleeve package		S
MEASUREMENT		
RENISHAW HPRA tool presetter		O
COOLANT		
Coolant pump	3 kg/cm ²	S
High-pressure coolant system	20 kg/cm ²	O
Roll-out coolant tank		S
Oil skimmer		O
Coolant flow switch		O
Coolant level switch		O
Coolant intercooler system		O
CHIP DISPOSAL		
Chip conveyor with auto timer	Right discharge	S
Chip cart with coolant drain		O
Chuck air blow		O
Coolant gun		O
Oil mist collector		O
SAFETY		
Fully enclosed guarding		S
Door interlock (incl. Mechanical lock)		S
Chuck cylinder stroke out - end check		S
Chuck cylinder check valve		S
Low hydraulic pressure detection switch		S
Over travel (soft limit)		S
Load monitoring function		O
OTHERS		
Florescent work light		S
Electrical cabinet	Heat exchanger	S
	A/C cooling system	O
Complete hydraulic system		S
Hydraulic oil intercooler system		S
Advanced auto lubrication system		S
Emergency maintenance electrical part package		S
Operation & maintenance manuals		S
Auto door		O

FANUC CONTROL FUNCTIONS		Oi-TF	31i
Display	10.4" color LCD	S	S
	Standard	S	-
Graphic function	Dynamic*1	O	S
	512K bytes	S	-
	1M bytes	-	S
Part program storage size	2M bytes	O	O
	4M bytes	-	O
	8M bytes	-	O
	Registerable programs	400	S
Oi-TF : each path	1,000	O	S
	31i : total	4,000	-
Tool offset pairs	99	-	S
	128	S	-
	200	O	O
	Oi-TF : each path	400	-
31i : total	499	-	O
	999	-	O
	2000	-	O
	Servo HRV control	HRV 3	S
Automatic data backup		S	S
Synchronous / Composite control		O	O
Inch / metric conversion		S	S
Polar coordinate interpolation		S	S
Cylindrical interpolation		S	S
Multiple repetitive cycle		S	S
Rigid tapping		S	S
Unexpected disturbance torque detection function		S	S
Spindle orientation		S	S
Spindle speed fluctuation detection		S	S
Embedded macro		O	O
Spindle synchronous control		S	S
Run hour and parts count display		S	S
Tool radius / Tool nose radius compensation		S	S
Polygon turning		S	S
Helical interpolation		O	O
Direct drawing dimension programming		S	S
Thread cutting retract		S	S
Variable lead threading		S	S
Multiple repetitive cycle II		S	S
Canned cycles for drilling		S	S
Tool nose radius compensation		S	S
Chamfering / Corner R		S	S
AI contour control I		O	S
Multi part program editing*2		S	S
Manual handle retrace		O	O
Manual intervention and return		S	O
External data input		S	S
Addition of custom macro		S	S
Increment system C		S	S
Run hour & parts counter		S	S
Auto power-off function		S	S
RS-232 port		S	S
Memory card input / output (CF + USB)		S	S
Ethernet		S	S

*1 Dynamic graphic display conflict to MANUAL GUIDE *i*, only can choose one to have.
 MANUAL GUIDE *i* is standard on 31i controller.

Specifications are subject to change without notice.

MACHINE SPECIFICATIONS

■ : Metric ■ : Inch

CAPACITY		GA-3600/W24
Max. swing diameter		Ø 930 mm 36.61"
Swing over saddle		Ø 650 mm 25.59"
Max. turning diameter		Ø 680 mm 26.77"
Hydraulic hollow 3-jaw chuck size		15"
Wheel size		13" ~ 24"
SPINDLE		
Spindle nose		A2-11
Hole through spindle		Ø 120 mm 4.72"
Spindle bearing diameter		Ø 160 mm 6.29"
Max. spindle speed		2,500 rpm
Spindle motor output (cont. / 30 min. / 15 min.)		30 / 37 / 45 kW 40 / 50 / 60 HP
Max. spindle torque		577 Nm 425 lb-ft
Max. bar bore		Ø 105 mm 4.13"
X & Z AXES		
X-axis travel		400 mm 15.74"
Z-axis travel		900 mm 35.43"
X / Z axes rapids		20 / 24 m/min. 788 / 945 IPM
X / Z axes servo motor		2.7 / 7 kW 3.6 / 9 HP
TURRET		
Stations		10
Indexing drive		AC Servo motor
O.D. / I.D. tool shank size		□32 mm 1-1/4" / Ø50 mm 2"
Indexing speed		0.3 sec. Adjacent / 0.5 sec. 180 degrees (Single step)
GENERAL		
Hydraulic tank capacity		40 L 10 gal
Coolant tank capacity		140 L 36 gal
Dimensions (L × W × H)		3,062 × 1,905 × 1,900 mm 121" x 75" x 75"
Machine weight		6,800 Kg 15,000 lb

Specifications are subject to change without notice.
Please refer to the manufacturer for max. speed of the aluminum-wheel hydraulic chuck.



GOODWAY MACHINE CORP.

HEADQUARTERS

No.13, 5th Road,
Taichung Industrial Park,
Taichung City, 407, Taiwan
E-mail : goodway@goodwaycnc.com

CENTRAL TAIWAN SCIENCE PARK BRANCH

No. 38, Keyuan Road,
Central Taiwan Science Park.Taichung,
Taichung City, 407, Taiwan
TEL : + 886-4-2463-6000
FAX : + 886-4-2463-9600

GOODWAY MACHINE (WUJIANG) CO.,LTD

No. 4888, East Lake Taihu Avenue, Wujiang
Economic and Technological Development Zone,
Jiangsu, China
Sales Hotline : + 86-512-8286-8068
Service Hotline : + 86-512-8286-8066
FAX : + 86-512-8286-8620
E-mail : goodway@goodwaycnc.cn