

DİK İŞLEME MERKEZLERİ

GÜÇLÜ. HASSAS. STABİL.

- Daha Güçlü,Dayanıklı ve optimum stabilite yapısı için Meehanit FC35 Döküm Kullanılmıştır.
- Tüm serilerimizde hassas ve güçlü lineer ve masura lineer kızaklar kullanılmıştır.
- 3 Eksendede yüksek torklu motorlar kullanılmıştır.
- Termal uzamalara karşı dayanıklı vidalı miller kullanılmıştır.
- Kompact makina yapısı sayesinde daha az yer kaplar.





SAĞLAM YAPI

- Ağır iş parçalarını hassas bir şekilde işleyebilir.
- 3 eksen kullanılan kızaklar teleskopik körükler ile korunmuştur.
- Yüksek rijitlikteki kolon ve kafa yapısı FEA ile incelenerek en yüksek sağlamlık ve stabilite sağlanmıştır.
- Özel dizayn edilmiş spindle yapısı sayesinde takım kullanımı kolaylaştırılmıştır.
- Kutu tipi head stock dizaynı.



MASURA LİNEER KIZAKLAR

GÜÇLÜ AKSESUARLAR İLE MAKİNE PERFORMANSI ARTTIRILMIŞTIR



4.EKSEN HAZIRLIĞI



24 VOLT İŞ LAMBASI



GRUNDFOS POMPA



3 EKSEN KABLO KORUMA



F.R.L. SİSTEM



SIEMENS VEYA SCHNEIDER
ELEKTRİK KOMPONENTLERİ



PALET TİPİ TALAŞ KONVEYÖRÜ
(OPSİYON)

Cutting Shape	Metallic	Palet Tipi Konveyör	Screw Tip Konveyör
Metal Talaşı		<input checked="" type="radio"/>	<input checked="" type="radio"/>
Döküm Talaşı		<input type="radio"/>	<input checked="" type="radio"/>
Alüminyum Talaşı (Kıvrık)		<input checked="" type="radio"/>	<input type="radio"/>
Alüminyum Talaşı		<input type="radio"/>	<input checked="" type="radio"/>
Metal Olmayan Talaş		<input checked="" type="radio"/>	<input checked="" type="radio"/>



OTOMATİK TAKIM BOYU ÖLÇME

Tüm makinalarımız daha hassas kesim ve iş gücünden daha fazla verim alabilmek adına hassas ve otomatik takım boyu ölçme problemleri ile donatılmıştır.

MASURA LİNEER KIZAKLAR

Yüksek hassasiyet ve ağır iş parçalarında rahat hareket için mazura lineer kızaklar kullanılmıştır (Model bazında farklılık gösterebilir).

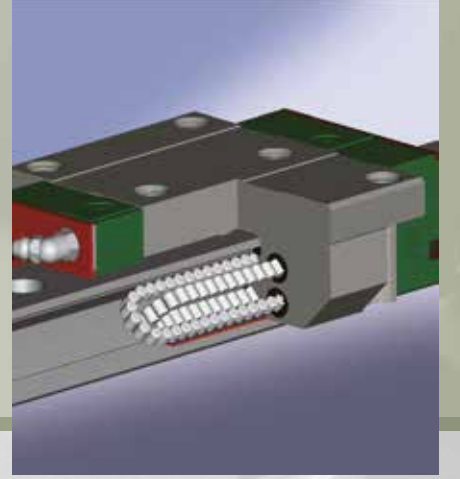

ÜSTÜN MAKİNA HASSASİYETİ

Montaj ve imalat aşamalarında ISO 10791 ile daha yüksek hassasiyet ve performans.

VİDALI MİL

Termal deformasyonlara dayanıklı vidalı miller kullanılmıştır.



10.4" RENKLİ EKİRAN (15" OPSİYON)

Operasyon konforunu arttırmak için daha büyük ekranlar kullanılmaktadır.

ÖZELLİKLER

		MCV-650	MCV-866	MCV-1166	MCV-1270
İŞ MİLİ					
İŞ MİLİ DEVRİ	r.p.m.	10000(12000,15000,20000,24000)	8000(10000,12000,15000) (BT50: 6000,8000,10000)		
İŞ MİLİ AKTARIM TİPİ		KAYIŞ(DIRECT DRIVE-BUILT IN)	KAYIŞ (DIRECT DRIVE-BUILT IN-ŞANZUMAN)		
İŞ MİLİ MOTOR GÜCÜ	kw	5.5/7.5 (7.5/11)	7.5/11(11/15,15/18.5)		
TABLA					
TABLA ÖLÇÜSÜ	mm	650 x 500	910 x 560	1160 x 600	1350 x 600
T-SLOT	mm	18 x 5 x 100			
MAX.PARÇA AĞIRLIĞI	kgs	300	800	1000	1200
EKSEN HAREKETLERİ					
X EKSENİ	mm	600	860	1100	1250
Y EKSENİ	mm	500	600		700
Z EKSENİ	mm	500	600		
FEED					
CUTTING FEED (X/Y/Z)	mm/min	10000	12000		
RAPID TRAVERS(X/Y/Z)	M/min	36(48)	30/30/24(36/36/30,48/48/36)		24(30/30/24)
MIN. INPUT INCREMENT	mm	0.001			
A.T.C.					
TAKIM TUTUCU TİPİ		BT40	BT40 (BT50)		
TAKIM İSTASYON ADEDİ	tool	24(30)	24(30,36) (BT50: 20, 24)		24(30,60) (BT50: 20,24)
MAX.TAKIM ÇAPI / YANLAR BOŞ	mm	Ø75 / Ø150			
MAX.TAKIM UZUNLUĞU	mm	300			
MAX.TAKIM AĞIRLIĞI	kgs	6	7		
TAKIM SEÇİMİ		EN KISA YOL ÜZERİNDEN			
MAKİNA AĞIRLIĞI VE ÖLÇÜLERİ					
TEZGAH OTORUM ALANI	mm	2660x2400	2960x2440	3660x2230	3960x2260
NET AĞIRLIK	kgs	4300	6000	7300	7400

STANDART AKSESUARLAR:

- KOLLU TİP TAKIM DEĞİŞTİRİCİ
- KAPALI KABİN
- İŞ LAMBASI VE UYARI LAMBASI
- OTOMATİK YAĞLAMA SİSTEMİ
- SOĞUTUCU ÜNİTE
- OTOMATİK KAPANMA
- RIGID TAPPING
- AVADANLIK SETİ
- TERAZİ AYAKLARI
- KİTAPLAR
- OTOMATİK TAKIM BOYU ÖLÇME PROBU
- FENERMİLİ İÇİNDEN SU VERME 30 BAR
- HAVA TABANCASI
- SU TABANCASI
- SCREW TİP TALAŞ KONVEYÖRÜ
- TRAFÖ

OPSİYONEL AKSESUARLAR:

- PALET TİPİ TALAŞ KONVEYÖRÜ
- LİNEER CETVEL
- OTOMATİK TAKIM BOYU ÖLÇME PROBU
- OTOMATİK PARÇA ÖLÇME SİSTEMİ
- ELEKTRİK KABİN KLİMASI
- 4.EKSEN HAZIRLIĞI (SOKET)
- PNOMATİK/HİDROLİK FİXTURE HAZIRLIĞI (HORTUM VE KABLO)

MCV-1370	MCV-1470	MCV-1570	MCV-1670	MCV-1618	MCV-1818	MCV-2018
8000(10000,12000,15000) (BT50: 6000,8000,10000)				6000(8000,1000) (BT40: 8000,10000,12000,15000)		
BELT(DIRECT, BUILT-IN, ZF GEAR BOX) 7.5/11(11/15,15/18.5)				BELT TYPE(GEAR,DIRECT, ZF GEAR BOX) 15/18.5 (18.5/22)		
1350 x 600	1500 x 600	1500 x 600	1600 x 600	1700 x 1000	1900 x 1000	2100 x 1000
18 x 5 x 100				18 x 7 x 125		
1200	1500	1500	1600	2200	2500	3000
1350	1400	1500	1600	1600	1800	2000
710				1020		
610				810		
12000				10000		
24(30/30/24)				20/20/15(24/24/20)		
0.001						
BT40 (BT50) 24(30,40,60) (BT50: 20,24)				BT50 (BT40) 24(32,40) (BT40: 24,30)		
Ø75 / Ø150				Ø110 / Ø200		
300				350		
7				15		
RANDOM						
3960x2660	4360x2660	4360x2660	4560x3800	4650x3750	4970x3750	5440x3750
7400	8100	8100	8400	17000	18000	20000

TORK DİYAGRAMLARI

HEIDENHAIN

Torque Characteristic Curve

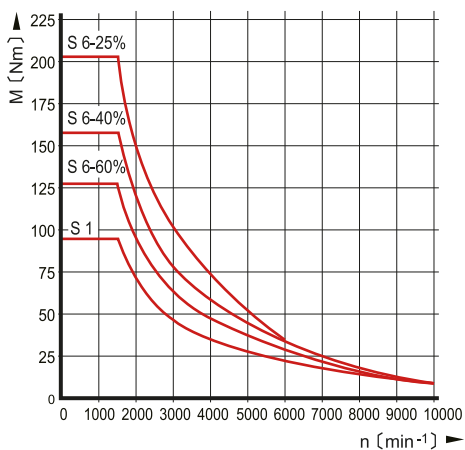

MISTUBISHI

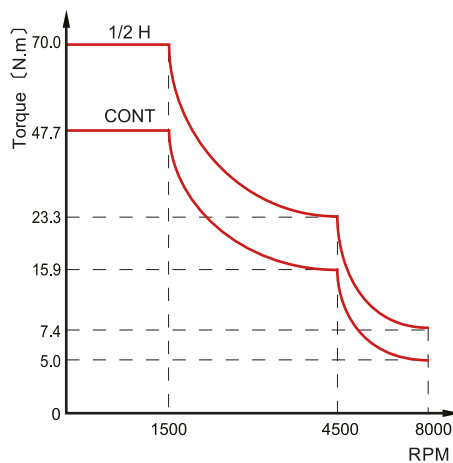

FANUC

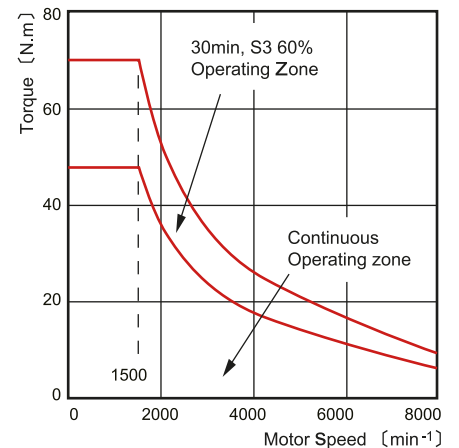

MAKİNA ÖLÇÜLERİ

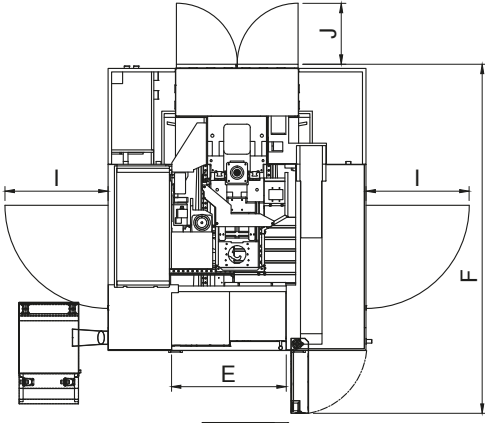

MODEL	A	B	C	D	E	F	G	H	I	J
650	1900	2660	2400	2300~2800	900	2740	780	820	885	530
866	2200	2960	2440	2510~3110	980	2980	920	675	885	530
1166	2900	3660	2230	2480~3080	1215	2770	940	655	885	530
1270	3200	3960	2260	2480~3080	1415	2800	940	655	885	530
1370	3200	3960	2260	2480~3080	1415	2800	940	655	885	530
1470	3600	4360	2260	2480~3080	1615	2800	940	655	885	530
1570	3600	4360	2260	2480~3080	1615	2800	940	655	885	530
1670	3800	4560	2260	2480~3080	1680	2800	940	655	885	530
1618	3890	4650	3750	2626~3462	1660	4750	970	600	885	610
1818	4210	4970	3750	2626~3462	1840	4750	970	600	885	610
2018	4680	5440	3750	2626~3462	2040	4750	970	600	885	700

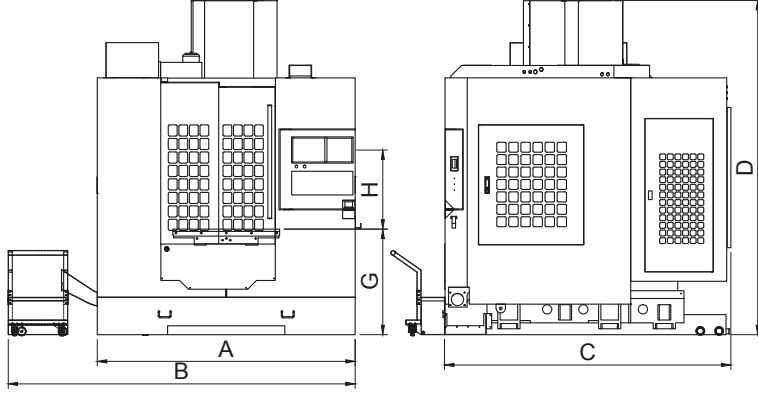

PULL STUD & TOOL SHANK

BT40

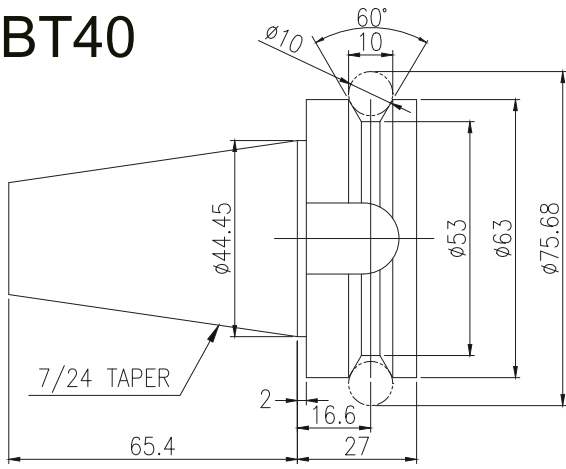

BT50

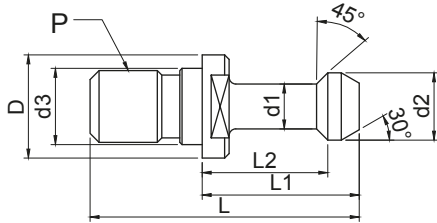
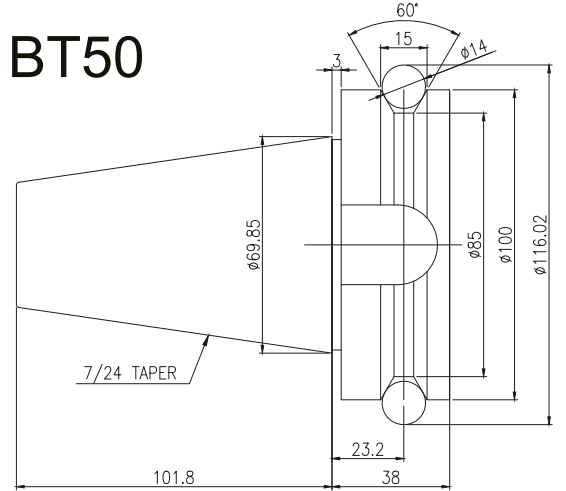

MODEL	D	d1	d2	d3	L	L1	L2	P
BT40	23	10	15	17	60	35	28	M16*2.0
BT50	38	17	23	25	85	45	35	M24*3.0

TABLA VE T-SLOT ÖLÇÜLERİ

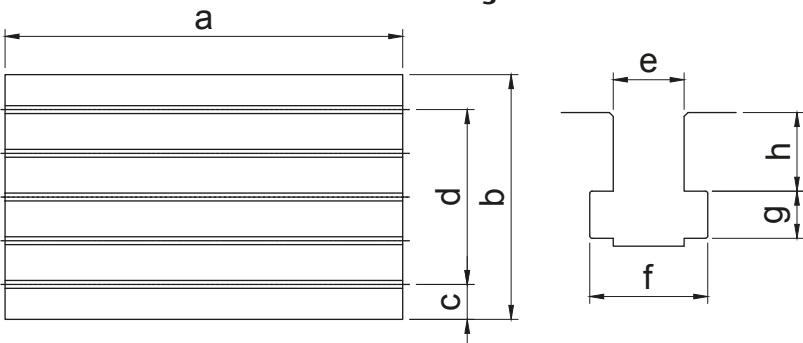

MODEL	a	b	c	d	e	f	g	h
650	650	500	50	4*100	18	30	12	20
866	910	560	80	4*100	18	30	12	20
1166	1160	600	100	4*100	18	30	14	18
1270	1350	600	100	4*100	18	30	14	18
1370	1350	600	100	4*100	18	30	14	18
1470	1500	600	100	4*100	18	30	14	18
1570	1500	600	100	4*100	18	30	14	18
1670	1600	600	100	4*100	18	30	14	18
1618	1700	1000	125	6*125	18	30	12	20
1818	1900	1000	125	6*125	18	30	12	20
2018	2100	1000	125	6*125	18	30	12	20

PALET DEĞİŞTİRMELİ MODELLER

ÖZELLİKLER

		MAP-650	MAP-856	MAP-1156
İŞ MİLİ				
İŞ MİLİ HIZI	r.p.m.	10000(12000,15000,20000,24000)	8000(10000,12000,15000) (BT50: 6000,8000,10000)	

TABLA

TABLA ÖLÇÜSÜ	mm	600 x 400	850 x 500	1000 x 500
MAX.PARÇA AĞIRLIĞI	kgs	200	250	300

EKSEN HAREKETLERİ

X EKSENİ	mm	610	860	1100
Y EKSENİ	mm	500	560	
Z EKSENİ	mm	500	600	

EKSEN HIZLARI

KESME İLERLEMESİ (X/Y/Z)	mm/min	10000	12000	
BOŞTA İLERLEME (X/Y/Z)	M/min	36(48)	36/36/30(48/48/36)	30/30/24(36/36/30)

A.T.C.

TUTUCU TİPİ	BT40	BT40 (BT50)		
TAKIM İSTASYON KAPASİTESİ	tool	24(30)	24(30,36) (BT50: 20, 24)	

MAKİNA AĞIRLIĞI VE ÖLÇÜLERİ

MAKİNA OTURMA ALANI	mm	3400x3200	3600x3460	3640x4160
NET AĞIRLIK	kgs	6000	8100	8700

STANDART AKSESUARLAR:

- KOLLU TİP TAKIM DEĞİŞTİRİCİ
- KAPALI KABİN
- İŞ LAMBASI VE UYARI LAMBASI
- OTOMATİK YAĞLAMA SİSTEMİ
- SOĞUTUCU ÜNİTE
- OTOMATİK KAPANMA
- RIGID TAPPING
- AVADANLIK SETİ
- TERAZİ AYAKLARI
- KİTAPLAR
- OTOMATİK TAKIM BOYU ÖLÇME PROBU
- FENERMİLİ İÇİNDEN SU VERME 30 BAR
- HAVA TABANCASI
- SU TABANCASI
- SCREW TİP TALAŞ KONVEYÖRÜ
- TRAFİO

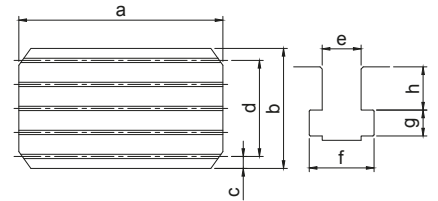
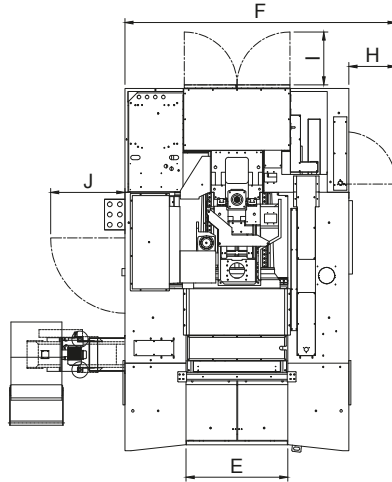

MODEL	a	b	c	d	e	f	g	h
MAP-650	600	400	100	2*100	14	24	10	18
MAP-856	850	500	50	4*100	18	32	13	18
MAP-1156	1000	500	50	4*100	18	32	13	18

MODEL	A	B	C	D	E	F	G	H	I	J
MAP-650	1980	3200	3400	2510-3010	760	2780	1010	470	520	730
MAP-856	2240	3460	3600	2660-3260	900	3080	1070	470	520	730
MAP-1156	2940	4160	3640	2660-3260	1200	3820	1070	470	520	730

OPSİYONEL AKSESUARLAR:

- HAVA TABANCASI
- SU TABANCASI
- FENERMİLİ İÇİNDEN SU VERME
- TRAFİO
- TALAŞ KONVEYÖRÜ
- LİNEER CETVEL
- OTOMATİK TAKIM BOYU ÖLÇME PROBU
- OTOMATİK PARÇA ÖLÇME SİSTEMİ
- ELEKTRİK KABİN KLİMASI
- 4.EKSEN HAZIRLIĞI (SOKET)
- PNOMATİK/HİDROLİK FİXTURE
- HAZIRLIĞI (HORTUM VE KABLO)

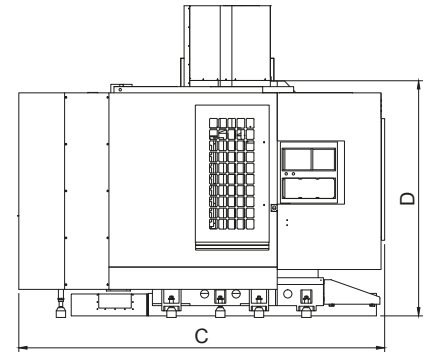
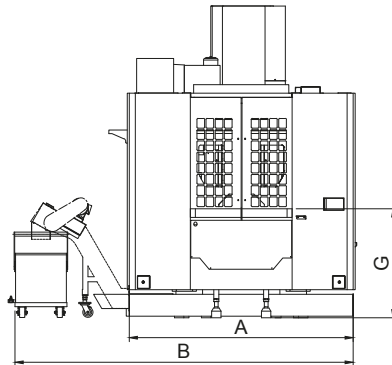

Frontier

**TEZMAKSAN MAKİNA
SANAYİ VE TİCARET A.Ş.**

Abdi İpekçi Caddesi No:129
Bayrampaşa / İstanbul
Tel: +90 212 674 60 10
Fax: +90 212 577 76 99
www.tezmaksan.com.tr

