

SMEC

SL 2500/3000 series

CNC TURNING CENTER



SMEC
SMEC CO.,LTD.

SMEC Co., Ltd.
157-10, Goldenroot-ro, Juchon-myeon,
Gimhae-si, Gyeongsangnam-do, Korea
Tel +82 55 340 4800
Fax +82 55 340 4740



www.esmec.com



https://www.youtube.com/c/smecmachinetools

SMEC
Smart One,
Global One

© SMEC 2019.07-NO.1

SMEC
SMEC CO.,LTD.

◆ Design and specifications subject to change without notice.

- 1988 - Started as Samsung Heavy Industries Machine Tools Business
- 1989 - Horizontal and vertical machining center technology partnership with OKK Japan
- 1991 - Turning center and vertical machining center technology partnership with Mori Seiki
- 1996 - 5-sided processing center technology partnership with Toshiba
- 1999 - Spun out from Samsung Aerospace Industries and established SMEC Co., Ltd

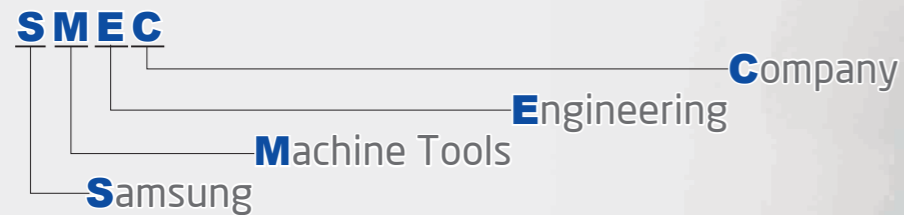

SL 2500 series (A Type : 8", B Type : 10")

SL 2500/X/L
SL 2500M/XM/LM

SL 3000 series (A Type : 10", B Type : 12")

SL 3000/X/L
SL 3000M/XM/LM

Strongest in its class with superb structural design
Simultaneous heavy duty and precision turning

- 45 degree torque tube type bed to support heavy duty turning
- Significantly reduced non-cutting time and efficient turning
- Low-center of gravity reducing vibration, thermal deformation and improving rigidity

High Accuracy, High Rigidity Spindle

Pin Tube Rib Design for Minimal Thermal Deformation

Radiator fan-like pin tube rib design dissipates heat generated by axis movements, maintaining minimal thermal expansion.



C-Axis

With C-axis control, users get synchronized control on 3axes which enables integrated processing, such as milling, drilling & rigid tapping.

SPINDLE & HEADSTOCK

The Spindle and Headstock are machined in a temperature controlled environment and assembled in a clean room.

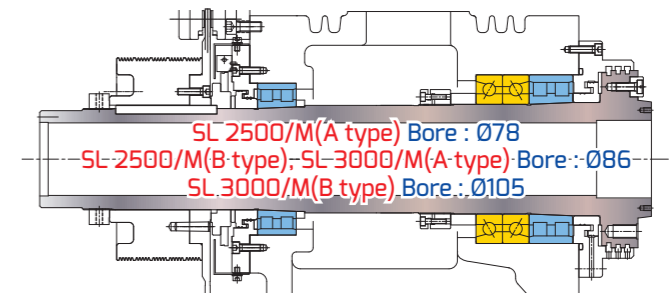

Precision double row cylindrical roller bearings and angular contact ball bearings are located at the front of the spindle, and a double row of cylindrical roller bearings is located in the rear to ensure heavy cutting capabilities with precision.

Spindle Power & Torque Diagram

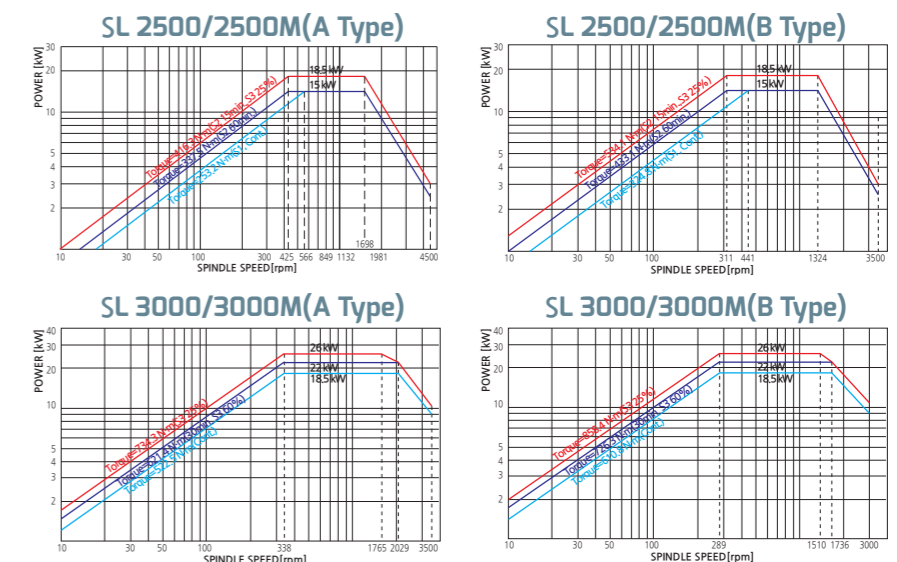

An innovative high precision, heavy duty CNC Lathe, integrated with all of SMEC's advanced technology - SL 2500/3000 series

Spindle motor(Cont./Max.)

15/18.5 kW (SL 2500 series)

18.5/26 kW (SL 3000 series)

Spindle speed

4,500 rpm [SL 2500 Series(A Type)]

3,500 rpm [SL 2500 Series(B Type)
SL 3000 Series(A Type)]

3,000 rpm [SL 3000 Series(B Type)]

Rapid traverse(X/Z)

24/30 m/min

Bar working diameter

68 mm [SL 2500 Series(A Type)]

77 mm [SL 2500 Series(B Type)
SL 3000 Series(A Type)]

91 mm [SL 3000 Series(B Type)]

Max. machining diameter

Ø430 mm [SL 2500/2500X/2500L(A, B Type)
SL 3000/3000X/3000L(A, B Type)]

Ø405 mm [SL 2500M/2500XM/2500LM(A, B Type)
SL 3000M/3000XM/3000LM(A, B Type)]

※ SL 2500 Series (A Type : 8°, B Type : 10°) / SL 3000 Series (A Type : 10°, B Type : 12°)



Highly Reliable and Rigid Structural Design

- One piece Meehanite casting with heavily ribbed torque tube design
- Rigid bed supports for powerful cutting
- Excellent vibration dampening and thermal displacement design

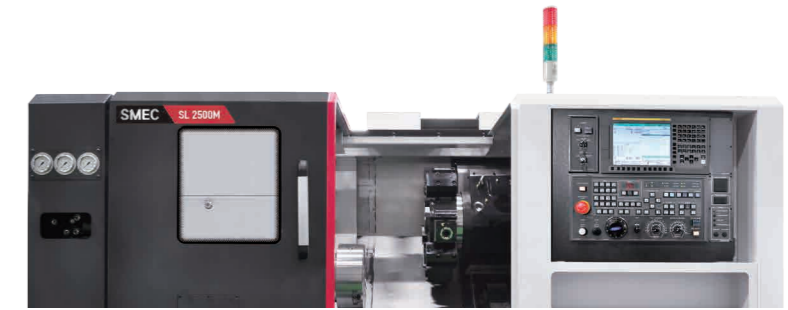

SL 2500/3000 Series (A, B Type)

High Speed, Heavy Duty Index Turret

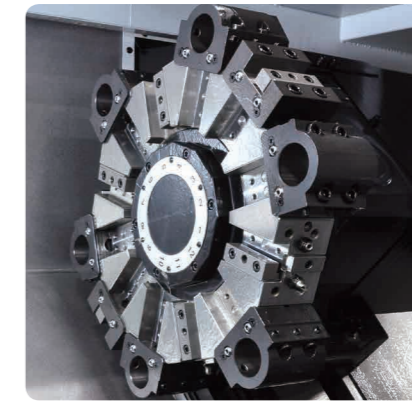

Indexing Time

0.2sec (60Hz)

Non-Cutting Time Significantly Reduced with Installation of High Speed Turret with 0.2 Sec Indexing Time

A 0.2 second 1 station indexing time is made possible by employing the Nonstop Random Index method using the SMEC developed high-power Servo Index Motor.

The large diameter Curvic Coupling significantly improves the clamping power and indexing precision.

Number of tool positions

12stations

SL 2500M/3000M Series (A, B Type)

High Speed Servo Turret (Tool Holder BMT65)

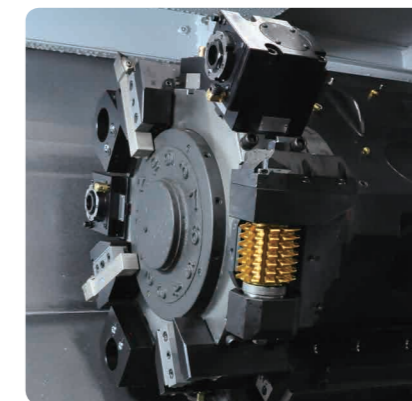

Turret Torque Diagram

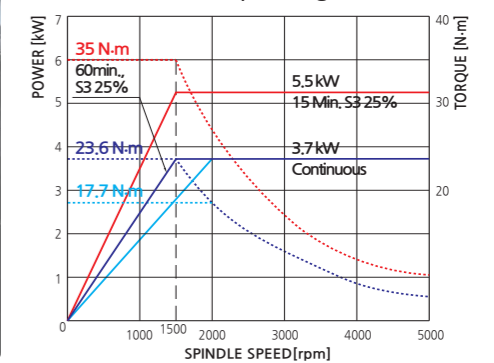

Easier HYD Valve Control

The gauge and control valve for HYD valve is raised to the operator's eye-level making maintenance easier.

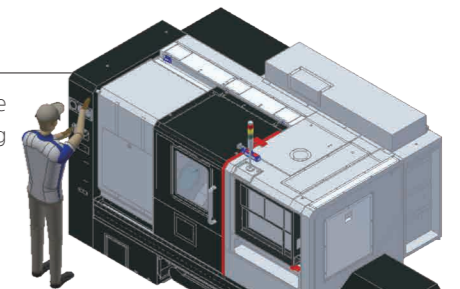

Easier Coolant Tank Cleaning

Cleaning the coolant tank is made easier with a coolant tank that can be removed while leaving the chip conveyor bolted to the machine. (AL/ALM/BL/BLM Series not included)

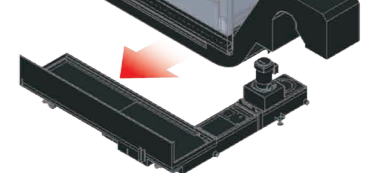



Centralized Operation Panel

The centralized operation panel with its 10.4 inch color TFT LCD monitor is able to swivel 90 degrees, providing operators with easy access to the control panel while working on the machine.



Main spindle height to minimize worker's fatigability
1,021mm

Rigid 45 degree Slant Bed

45 degree slant torque tube design bed and wide guide slide way ensure long term rigidity and machining accuracy.

Also, the Slant Type structure allows for easier access to the workpiece and superb chip discharge.

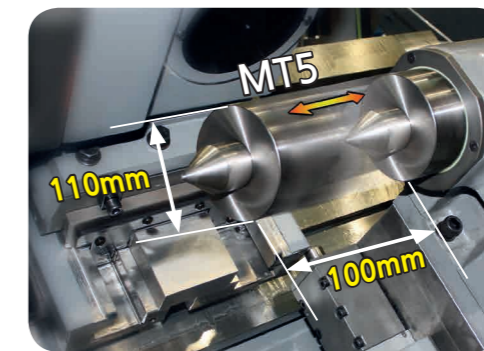
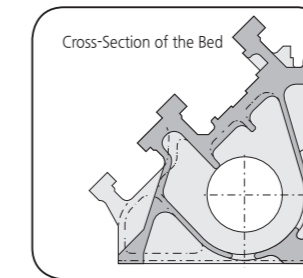

Programmable Tailstock(STD.)

The tailstock that maintains superb high precision during heavy duty cutting can be manually traversed using the MPG handle. Also, when the programmable tailstock is mounted, the tailstock and quill may be operated back and forth automatically using M-codes.

Pre-tensioned and Double Anchored Ballscrews

All axes ballscrews are pre-tensioned, heat treated and fixed by double anchors on both ends, providing ultimate rigidity and minimal thermal growth.

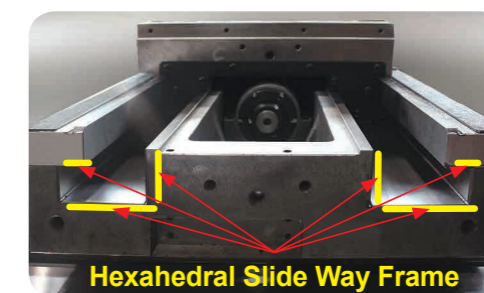
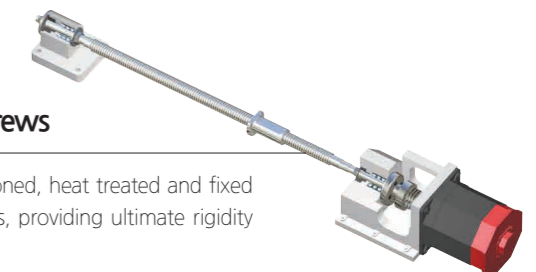

Hexahedral Slide Way Frame (X-axis)

Wide integral way is machined from the casting, induction hardened and precision ground to ensure long-term rigidity, machining accuracy and heavy-duty machining.

High Precision

Surface Roughness

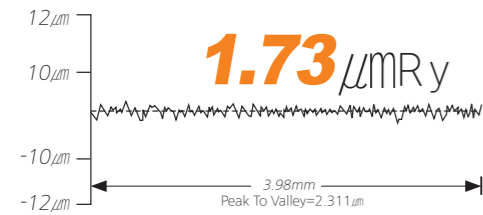

Model : SL 2500M

Roundness

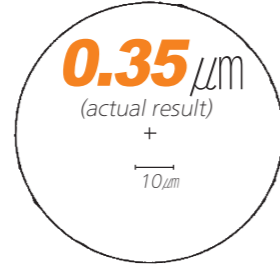

Cutting condition	
Tool	Diamond tool <nose radius 0.020 inch>
Material	AL150<Aluminum>
Cutting speed	230 m/min
Feedrate	0.05 mm/rev
Depth of cut	0.1 mm
Outer diameter	200 mm
Filter	1-50

Processing Speed

Turning Performance (material:SM45C) SL 2500A

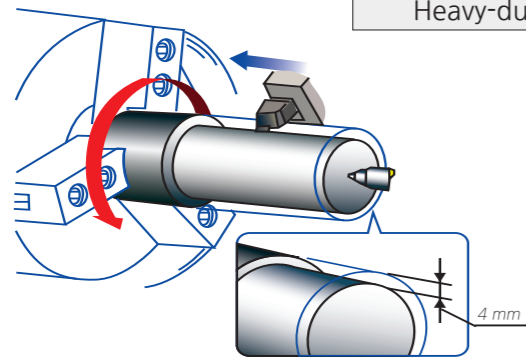

Heavy-duty cutting (O.D) <25mm×25mm qualified tool>

Spindle speed
524 rpm
Cutting speed
250m/min
Depth of cut
4 mm <Spindle Load 50%>
Feedrate
0.4 mm/rev

Optional Accessories

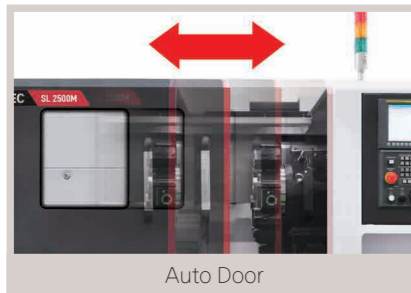
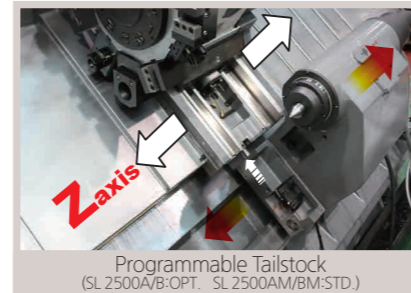
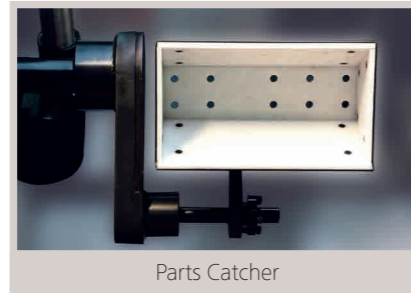

Tooling System

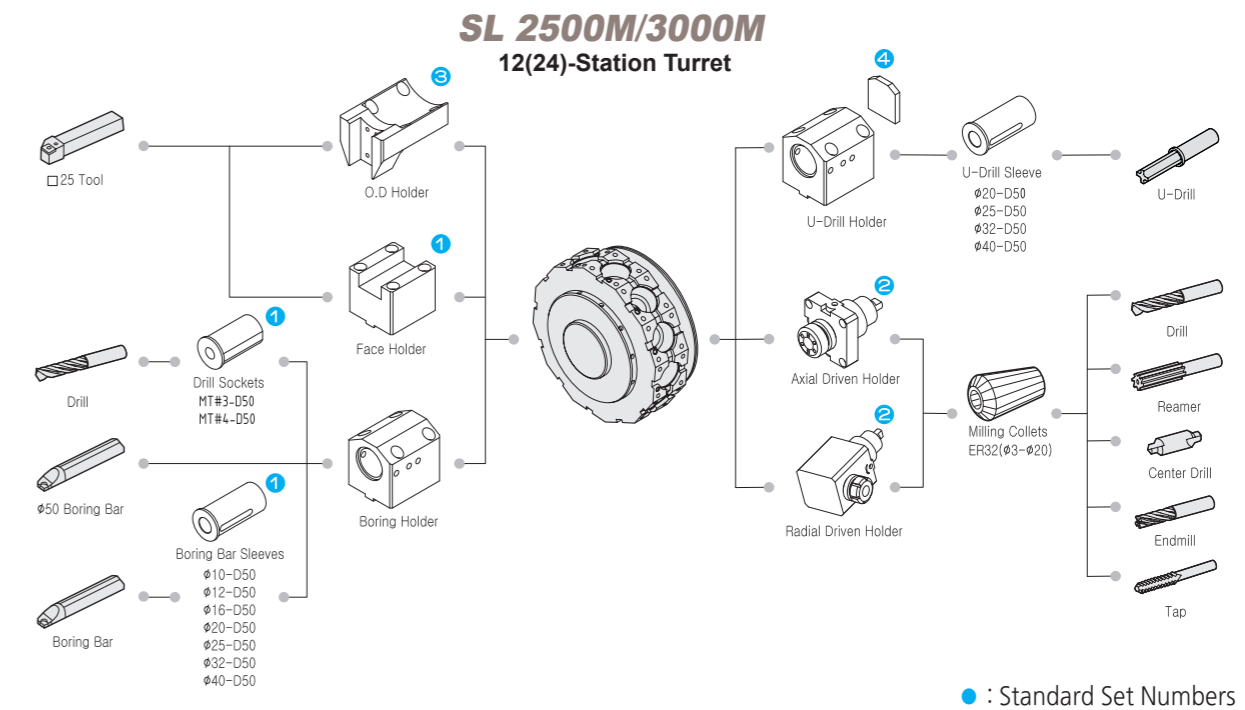
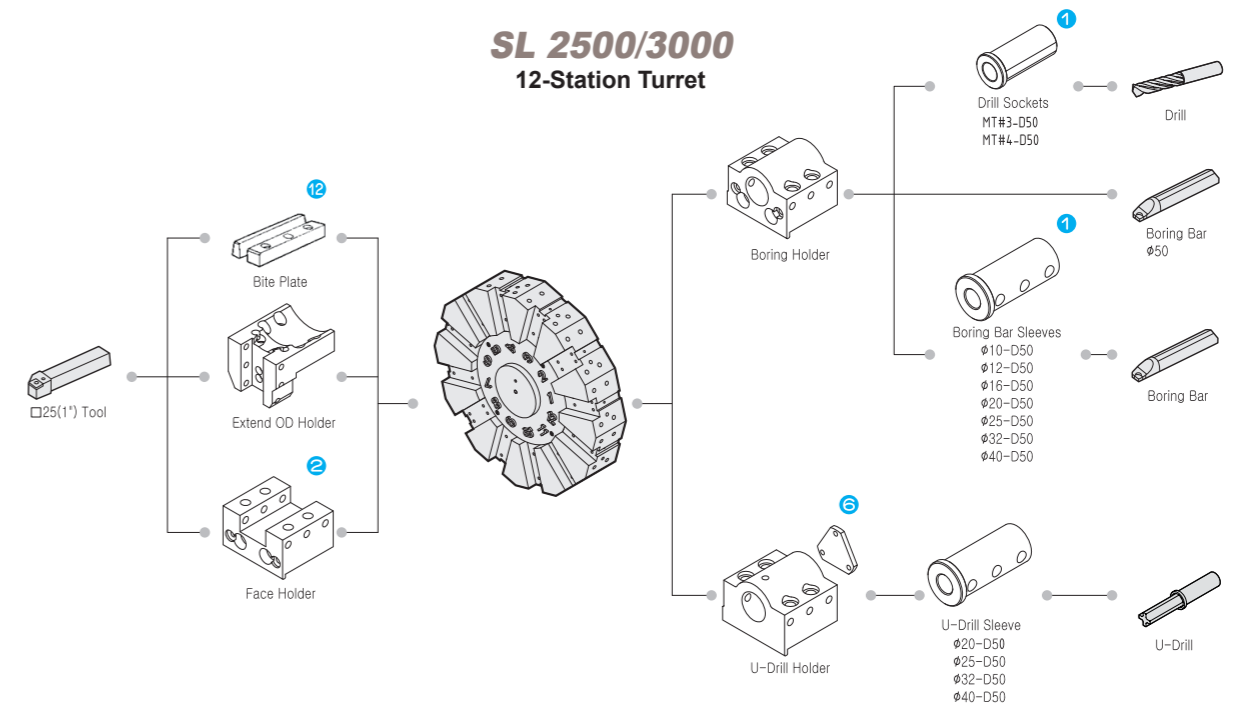

● : Standard Set Numbers

Machine Dimensions

Unit : mm

SL 2500/3000 series



SL 2500X/3000X(2500L/3000L) series

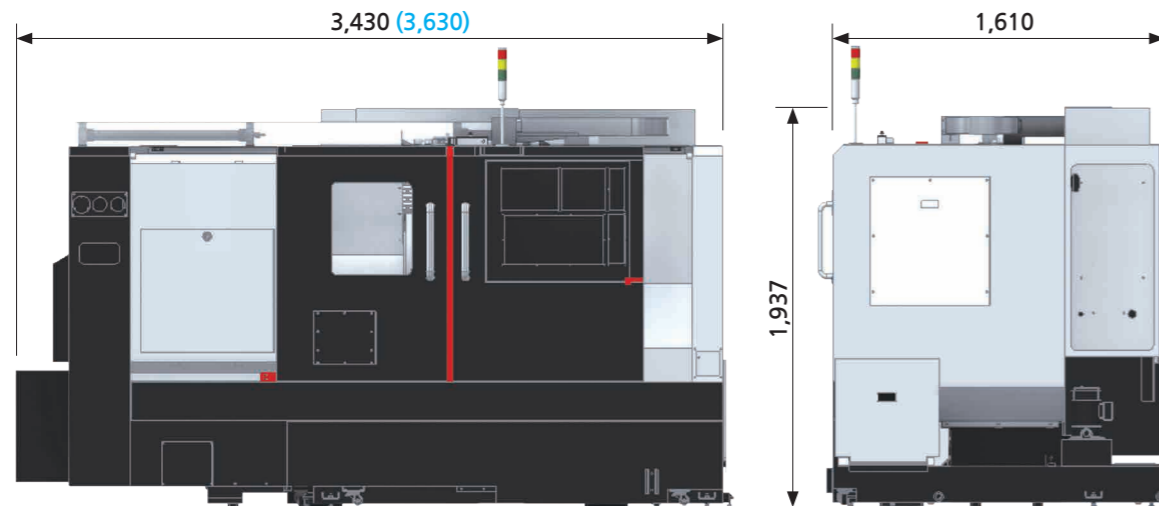

Standard Accessories

- 8" hollow 3 jaws chuck (SL 2500A Type)
- 10" hollow 3 jaws chuck (SL 2500B/3000A Type)
- 12" hollow 3 jaws chuck (SL 3000B Type)
- Chuck clamp confirmation
- Chuck clamp foot switch
- Chuck pressure switch
- Coolant system
- Door interlock
- Full splash guard with coolant tank
- Jaw (soft 3set, hard 1set)
- Leveling unit
- Manual/Part list (1set)
- Patrol lamp (3colors)
- Safety precaution name plate
- Spindle orientation
- Tailstock (programmable)
- Tool box
- Tool holders
- Work light (LED lamp)

Optional Accessories

- Air blower
- Air conditioner (electric cabinet)
- Air gun
- Auto door
- Auto shutter (top)
- Bar Feeder Interface
- Chip bucket
- Chip conveyor (side, rear)
- Coolant blower
- Coolant chiller
- Coolant gun
- Coolant level switch
- Counter (total, multi, tool, work)
- Dual pressure chucking
- Oil mist collector
- Oil skimmer
- Part catcher
- Robot interface
- Special chuck
- Steady rest
- Tool presetter (manual/auto)
- Transformer

Turret Interference

Unit : mm

SL 2500/3000 series

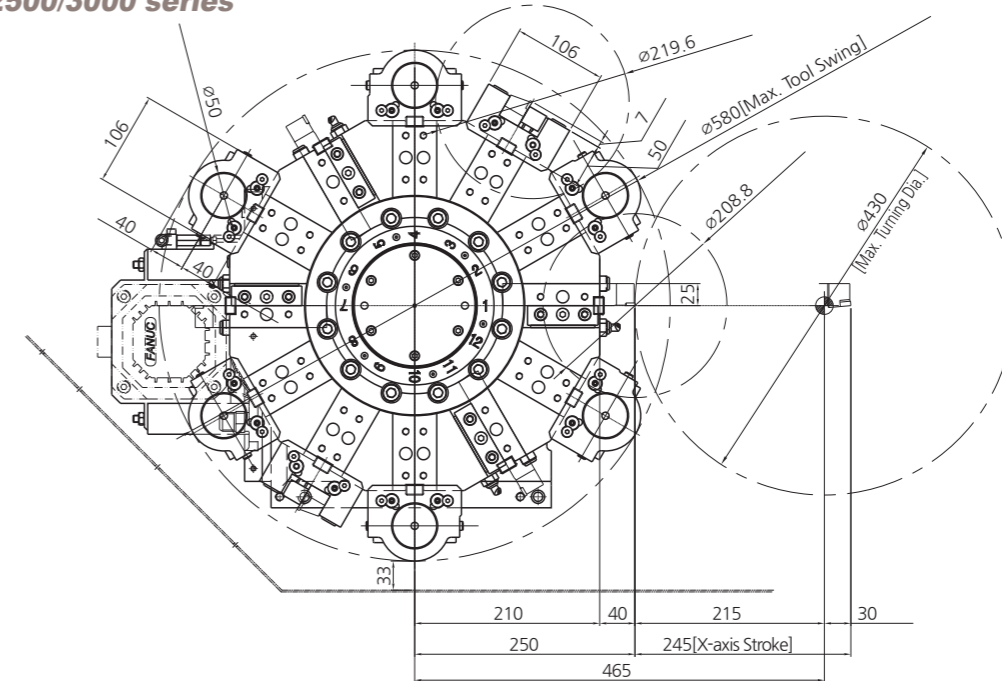

SL 2500M/3000M series

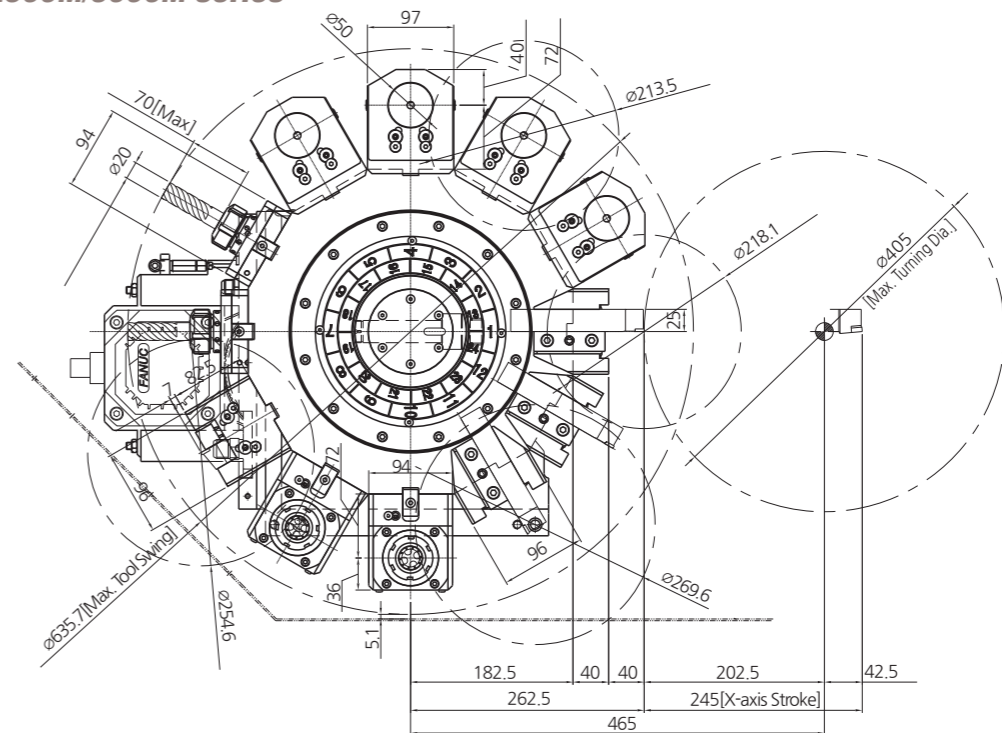

Work Range

Unit : mm

SL 2500/3000 series

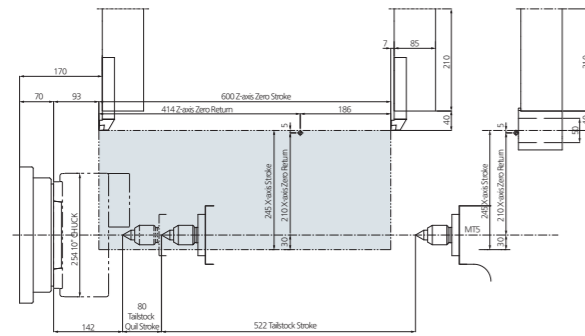

SL 2500M/3000M series

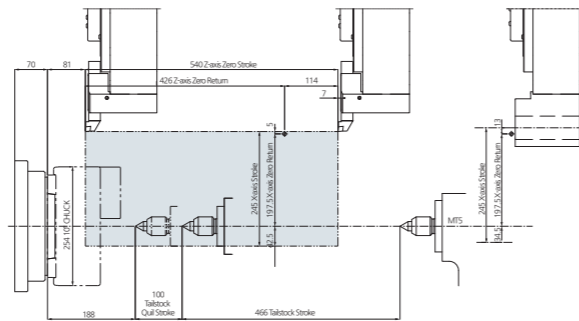

SL 2500X/3000X series

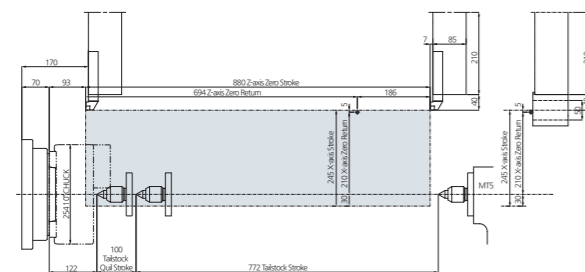

SL 2500XM/3000XM series

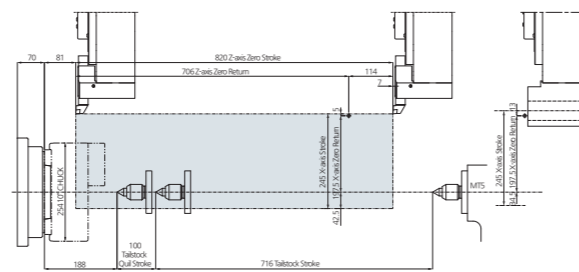

SL 2500L/3000L series

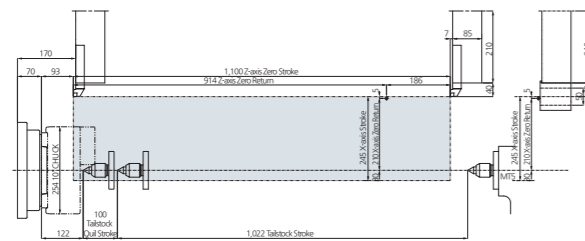

SL 2500LM/3000LM series

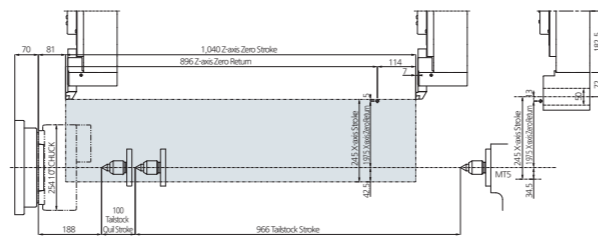

Major Specifications

DESCRIPTION	SL 2500		SL 2500M			
	A type	B type	A type	B type		
Chuck	Chuck size	inch	8"	10"	8"	10"
Capacity	Swing over bed	mm	650	650	650	650
	Swing over cross slide	mm	480	480	480	480
	Max. turning diameter	mm	430	430	405	405
Capacity	Max. milling diameter	mm	-	-	526	526
	Max. machining length	mm	570	554	504	497
Spindle	Spindle speed	rpm	4,500	3,500	4,500	3,500
	Spindle nose	ASA	A2-6	A2-8	A2-6	A2-8
	Draw tube ID	mm	68	77	68	77
	Spindle bore diameter	mm	78	86	78	86
	Motor (Cont./Max)	kW	15/18.5	15/18.5	15/18.5	15/18.5
Travels	X-axis travel	mm	245	245	245	245
	Z-axis travel	mm	600	600	540	540
	X-axis Rapid travers rate	m/min	24	24	24	24
	Z-axis Rapid travers rate	m/min	30	30	30	30
Turret	Number of tool stations	ea	12	12	12[24] (BMT65)	12[24] (BMT65)
	Turning tool shank size	mm	25	25	25	25
	Boring bar diameter	mm	50	50	50	50
	Turret index time(next station swivel time)	sec	0.20	0.20	0.20	0.20
	Rotary tool speed	rpm	-	-	5,000	5,000
	Rotary tool motor (Cont./Max)	kW	-	-	3.7/5.5	3.7/5.5
Tailstock	Quill diameter	mm	110	110	110	110
	Quill stroke	mm	100	100	100	100
	Spindle taper	MT	MT5	MT5	MT5	MT5
Machine	Size (with Side Chip conveyor) LxWxH	mm	3,125(4,230) × 1,610 × 1,937		3,125(4,230) × 1,610 × 1,937	
	Size (with Rear Chip conveyor) LxWxH	mm	3,125 × 1,990(2,530) × 1,937		3,125 × 1,990(2,530) × 1,937	
	weight	kg	5,100	5,100	5,100	5,200
	Coolant tank capacity	Liter	175	175	175	175
ELECTRIC POWER SUPPLY	kVA/V	34/220	34/220	34/220	34/220	
CONTROLLER		FANUC, SIEMENS				

※ Design and specifications subject to change without notice.

[] : Option

Major Specifications

DESCRIPTION			SL 2500X		SL 2500XM	
			A type	B type	A type	B type
Chuck	Chuck size	inch	8"	10"	8"	10"
Capacity	Swing over bed	mm	650	650	650	650
	Swing over cross slide	mm	480	480	480	480
	Max. turning diameter	mm	430	430	405	405
	Max. milling diameter	mm	-	-	433	433
	Max. machining length	mm	850	834	784	767
Spindle	Spindle speed	rpm	4,500	3,500	4,500	3,500
	Spindle nose	ASA	A2-6	A2-8	A2-6	A2-8
	Draw tube ID	mm	68	77	68	77
	Spindle bore diameter	mm	78	86	78	86
	Motor (Cont./Max)	kW	15/18.5	15/18.5	15/18.5	15/18.5
Travels	X-axis travel	mm	245	245	245	245
	Z-axis travel	mm	880	880	820	820
	X-axis Rapid travers rate	m/min	24	24	24	24
	Z-axis Rapid travers rate	m/min	30	30	30	30
Turret	Number of tool stations	ea	12	12	12[24] (BMT65)	12[24] (BMT65)
	Turning tool shank size	mm	25	25	25	25
	Boring bar diameter	mm	50	50	50	50
	Turret index time(next station swivel time)	sec	0.2	0.2	0.2	0.2
	Rotary tool speed	rpm	-	-	5,000	5,000
	Rotary tool motor (Cont./Max)	kW	-	-	3.7/5.5	3.7/5.5
Tailstock	Quill diameter	mm	110	110	110	110
	Quill stroke	mm	100	100	100	100
	Spindle taper	MT	MT5	MT5	MT5	MT5
Machine	Size (with Side Chip conveyor) L×W×H	mm	3,430(4,535) × 1,610 × 1,937		3,125(4,230) × 1,610 × 1,937	
	Size (with Rear Chip conveyor) L×W×H	mm	-		-	
	weight	kg	5,700	5,700	5,700	5,800
	Coolant tank capacity	Liter	200	200	200	200
ELECTRIC POWER SUPPLY		kVA/V	34/220	34/220	34/220	34/220
CONTROLLER			FANUC, SIEMENS			

※Design and specifications subject to change without notice.

[] : Option

Major Specifications

DESCRIPTION			SL 2500L		SL 2500LM	
			A type	B type	A type	B type
Chuck	Chuck size	inch	8"	10"	8"	10"
Capacity	Swing over bed	mm	650	650	650	650
	Swing over cross slide	mm	480	480	480	480
	Max. turning diameter	mm	430	430	405	405
	Max. milling diameter	mm	-	-	433	433
	Max. machining length	mm	1,070	1,054	1,004	997
Spindle	Spindle speed	rpm	4,500	3,500	4,500	3,500
	Spindle nose	ASA	A2-6	A2-8	A2-6	A2-8
	Draw tube ID	mm	68	77	68	77
	Spindle bore diameter	mm	78	86	78	86
	Motor (Cont./Max)	kW	15/18.5	15/18.5	15/18.5	15/18.5
Travels	X-axis travel	mm	245	245	245	245
	Z-axis travel	mm	1,100	1,100	1,040	1,040
	X-axis Rapid travers rate	m/min	24	24	24	24
	Z-axis Rapid travers rate	m/min	30	30	30	30
Turret	Number of tool stations	ea	12	12	12[24] (BMT65)	12[24] (BMT65)
	Turning tool shank size	mm	25	25	25	25
	Boring bar diameter	mm	50	50	50	50
	Turret index time(next station swivel time)	sec	0.2	0.2	0.2	0.2
	Rotary tool speed	rpm	-	-	5,000	5,000
	Rotary tool motor (Cont./Max)	kW	-	-	3.7/5.5	3.7/5.5
Tailstock	Quill diameter	mm	110	110	110	110
	Quill stroke	mm	100	100	100	100
	Spindle taper	MT	MT5	MT5	MT5	MT5
Machine	Size (with Side Chip conveyor) L×W×H	mm	3,630(4,685) × 1,610 × 1,937		3,630(4,685) × 1,610 × 1,937	
	Size (with Rear Chip conveyor) L×W×H	mm	-		-	
	weight	kg	6,300	6,300	6,300	6,400
	Coolant tank capacity	Liter	220	220	220	220
ELECTRIC POWER SUPPLY		kVA/V	34/220	34/220	34/220	34/220
CONTROLLER			FANUC, SIEMENS			

※Design and specifications subject to change without notice.

[] : Option

Major Specifications

DESCRIPTION			SL 3000		SL 3000M	
			A type	B type	A type	B type
Chuck	Chuck size	inch	10"	12"	10"	12"
Capacity	Swing over bed	mm	650	650	650	650
	Swing over cross slide	mm	480	480	480	480
	Max. turning diameter	mm	430	430	405	405
	Max. milling diameter	mm	-	-	433	433
	Max. machining length	mm	554	528	497	456
Spindle	Spindle speed	rpm	3,500	3,000	3,500	3,000
	Spindle nose	ASA	A2-8	A2-8	A2-8	A2-8
	Draw tube ID	mm	77	91	77	91
	Spindle bore diameter	mm	86	105	86	105
	Motor (Cont./Max)	kW	18.5/26	18.5/26	18.5/26	18.5/26
Travels	X-axis travel	mm	245	245	245	245
	Z-axis travel	mm	600	600	540	540
	X-axis Rapid travers rate	m/min	24	24	24	24
	Z-axis Rapid travers rate	m/min	30	30	30	30
Turret	Number of tool stations	ea	12	12	12[24] (BMT65)	12[24] (BMT65)
	Turning tool shank size	mm	25	25	25	25
	Boring bar diameter	mm	50	50	50	50
	Turret index time(next station swivel time)	sec	0.20	0.20	0.20	0.20
	Rotary tool speed	rpm	-	-	5,000	5,000
	Rotary tool motor (Cont./Max)	kW	-	-	3.7/5.5	3.7/5.5
Tailstock	Quill diameter	mm	110	110	110	110
	Quill stroke	mm	100	100	100	100
	Spindle taper	MT	MT5	MT5	MT5	MT5
Machine	Size (with Side Chip conveyor) L×W×H	mm	3,125(4,230) × 1,610 × 1,937		3,125(4,230) × 1,610 × 1,937	
	Size (with Rear Chip conveyor) L×W×H	mm	3,125 × 1,990(2,530) × 1,937		3,125 × 1,990(2,530) × 1,937	
	weight	kg	5,200	5,200	5,200	5,300
	Coolant tank capacity	Liter	175	175	175	175
ELECTRIC POWER SUPPLY		kVA/V	41/220	41/220	41/220	41/220
CONTROLLER			FANUC, SIEMENS			

※Design and specifications subject to change without notice.

[] : Option

Major Specifications

DESCRIPTION			SL 3000X		SL 3000XM	
			A type	B type	A type	B type
Chuck	Chuck size	inch	10"	12"	10"	12"
Capacity	Swing over bed	mm	650	650	650	650
	Swing over cross slide	mm	480	480	480	480
	Max. turning diameter	mm	430	430	405	405
	Max. milling diameter	mm	-	-	433	433
	Max. machining length	mm	834	808	767	736
Spindle	Spindle speed	rpm	3,500	3,000	3,500	3,000
	Spindle nose	ASA	A2-8	A2-8	A2-8	A2-8
	Draw tube ID	mm	77	91	77	91
	Spindle bore diameter	mm	86	105	86	105
	Motor (Cont./Max)	kW	18.5/26	18.5/26	18.5/26	18.5/26
Travels	X-axis travel	mm	245	245	245	245
	Z-axis travel	mm	880	880	820	820
	X-axis Rapid travers rate	m/min	24	24	24	24
	Z-axis Rapid travers rate	m/min	30	30	30	30
Turret	Number of tool stations	ea	12	12	12[24] (BMT65)	12[24] (BMT65)
	Turning tool shank size	mm	25	25	25	25
	Boring bar diameter	mm	50	50	50	50
	Turret index time(next station swivel time)	sec	0.20	0.20	0.20	0.20
	Rotary tool speed	rpm	-	-	5,000	5,000
	Rotary tool motor (Cont./Max)	kW	-	-	3.7/5.5	3.7/5.5
Tailstock	Quill diameter	mm	110	110	110	110
	Quill stroke	mm	100	100	100	100
	Spindle taper	MT	MT5	MT5	MT5	MT5
Machine	Size (with Side Chip conveyor) L×W×H	mm	3,430(4,535) × 1,610 × 1,937		3,125(4,230) × 1,610 × 1,937	
	Size (with Rear Chip conveyor) L×W×H	mm	-		-	
	weight	kg	5,800	5,800	5,800	5,900
	Coolant tank capacity	Liter	200	200	200	200
ELECTRIC POWER SUPPLY		kVA/V	41/220	41/220	41/220	41/220
CONTROLLER			FANUC, SIEMENS			

※Design and specifications subject to change without notice.

[] : Option

Major Specifications

DESCRIPTION			SL 3000L		SL 3000LM	
			A type	B type	A type	B type
Chuck	Chuck size	inch	10"	12"	10"	12"
Capacity	Swing over bed	mm	650	650	650	650
	Swing over cross slide	mm	480	480	480	480
	Max. turning diameter	mm	430	430	405	405
	Max. milling diameter	mm	-	-	433	433
	Max. machining length	mm	1,054	1,028	997	956
Spindle	Spindle speed	rpm	3,500	3,000	3,500	3,000
	Spindle nose	ASA	A2-8	A2-8	A2-8	A2-8
	Draw tube ID	mm	77	91	77	91
	Spindle bore diameter	mm	86	105	86	105
	Motor (Cont./Max)	kW	18.5/26	18.5/26	18.5/26	18.5/26
Travels	X-axis travel	mm	245	245	245	245
	Z-axis travel	mm	1,100	1,100	1,040	1,040
	X-axis Rapid travers rate	m/min	24	24	24	24
	Z-axis Rapid travers rate	m/min	30	30	30	30
Turret	Number of tool stations	ea	12	12	12[24] (BMT65)	12[24] (BMT65)
	Turning tool shank size	mm	25	25	25	25
	Boring bar diameter	mm	50	50	50	50
	Turret index time(next station swivel time)	sec	0.20	0.20	0.20	0.20
	Rotary tool speed	rpm	-	-	5,000	5,000
	Rotary tool motor (Cont./Max)	kW	-	-	3.7/5.5	3.7/5.5
Tailstock	Quill diameter	mm	110	110	110	110
	Quill stroke	mm	100	100	100	100
	Spindle taper	MT	MT5	MT5	MT5	MT5
Machine	Size (with Side Chip conveyor) L×W×H	mm	3,630(4,685) × 1,610 × 1,937		3,630(4,685) × 1,610 × 1,937	
	Size (with Rear Chip conveyor) L×W×H	mm	-		-	
	weight	kg	6,400	6,400	6,400	6,500
	Coolant tank capacity	Liter	220	220	220	220
ELECTRIC POWER SUPPLY		kVA/V	41/220	41/220	41/220	41/220
CONTROLLER			FANUC, SIEMENS			

※ Design and specifications subject to change without notice.

[] : Option

NC Specifications / Fanuc Series

Item		Description
Controlled axes	Controlled axes	2-axis(X,Z)
	Max. simultaneously controlled axes	Positioning(G00) / Linear Interpolation(G01) Circular Interpolation(G02, G03)
Spindle function	Least input increment	0.001mm
	Spindle speed control	S5 (5 Digit)
	Spindle speed override	0~120%
	Spindle orientation	M19
Feed function	Feedrate override (10% increase)	0~150%
	Dwell	G04
	Reference position return	G27, G28
	Manual pulse generator	0.001/0.01/0.1mm
	Dry run	F0(Fine Feed), 25/50/100%
Tool function	Rapid traverse override	F0(Fine Feed), 25/50/100%
	Tool number command	T2(2 Digit), T4(Digit)
	Tool nose radius compensation	G40 ~ G42
	Tool offset pairs	128EA
Programming function	Tool geometry / wear offset	GEOMETRY & WEAR DATA
	Canned cycle	G70~G72, G74~G76
	Decimal point input	Able to input up to decimal point
	SUB program	4 phase
Tape Functions	Work coordinate system	G52~G59
	Max program dimension	±99999.999mm
	M function	M3 (3 digit)
	Input code	ISO/EIA auto recognition
	I/O interface	RS232C
Other features	Program storage space	1280M(512kb)
	Number of stored programs	400ea
	Display unit / MDI	8.4" color LCD / Soft input type MDI
	Display unit / MDI	10.4" color LCD / Soft input type MDI
	Synchronized tapping	Rigid tapping function
	Background editing	Program saving / editing during automatic operation
	Backlash compensation	Pitch error offset compensation for each axis
	Search function	Sequence / program number search
	Safety function	Emergency stop / overtravel
	Program test function	Machine Lock / Single Block
	Control function	Memory / MDI / Manual
	Mirror image	
Run hour and parts count display		
Custom macro	#100 ~ #199, #500 ~ #999	