

MCH-630

MCV-720

VERTICAL MACHINING CENTER

MCV-1020A

# MCV-1680

MCV-1020BA

MCV-1200

MCV-1250

MCV-1450

MCV-1700

MCV-2100

MCV-2600

DCM-2213



**DAH LIH MACHINERY INDUSTRY CO., LTD.**

No. 3, Kung-Yeh Lane, Fengcheng Road, Nanshih Village,

Wufeng District, Taichung City, 41357, Taiwan.

TEL:886-4-23334567 FAX:886-4-23307567

E-mail:export.sale@dahliah.com.tw Http://www.dahliah.com.tw



022-D2-00-022

1000.06.2016

The Latest and Best Quality Machinery.  
**DAHLIH**®

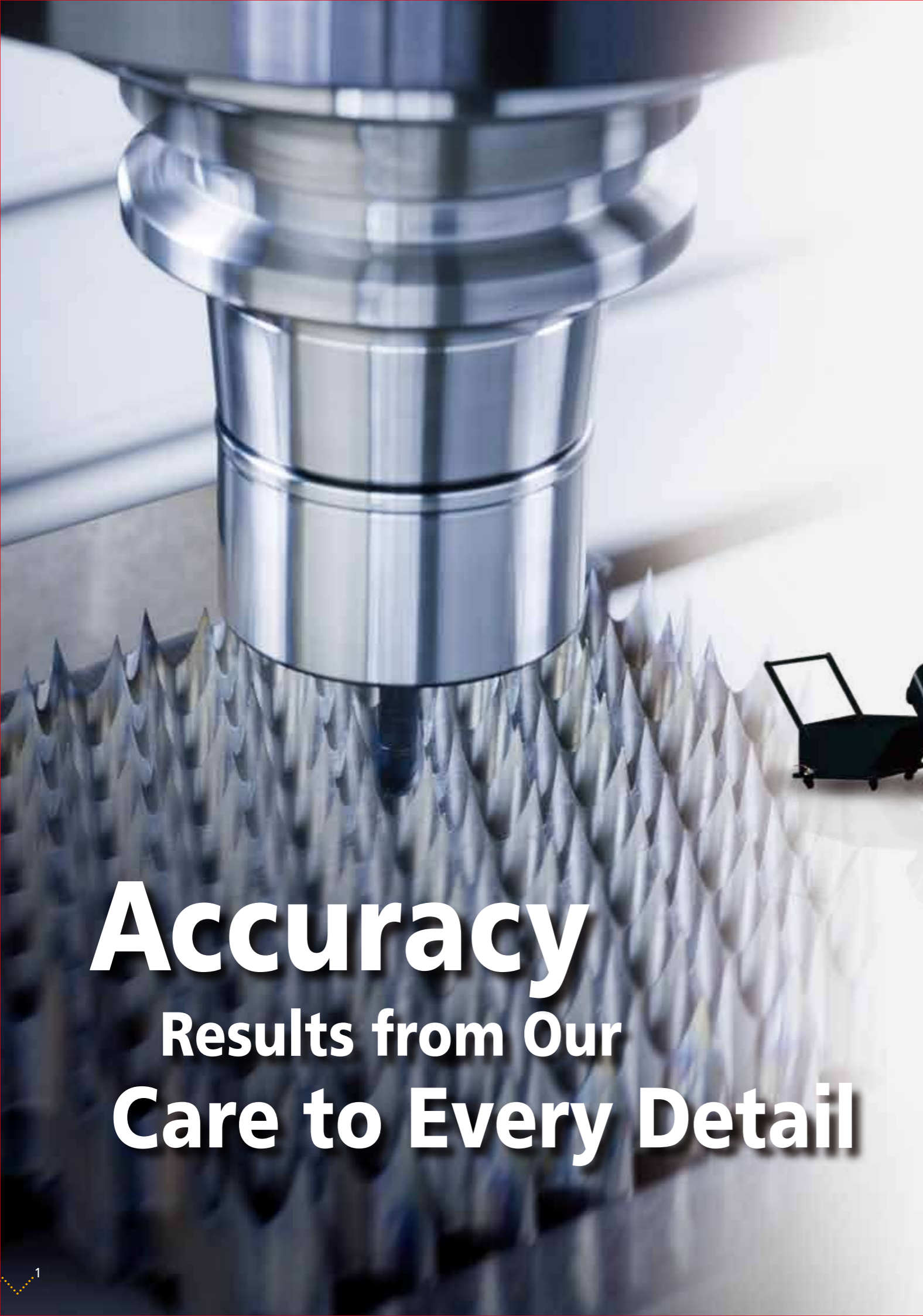

# Accuracy Results from Our Care to Every Detail

## MCV-1680

### VERTICAL MACHINING CENTER A Perfect Combination of High Speed And High Precision Machining

Built for high speed and high precision machining, Dah Lih's MCV-1680 Vertical Machining Center is a profitable performer in precision molds and general machining. The base of MCV-1680 is mounted with 4 precision linear guideways, so that it will exhibit extra high stability during high speed machining. This machine is equipped with a BBT40 face and taper spindle, 12000 rpm high speed spindle, and X, Y, Z-axis rapid traverse rates of 36/36/20 m/min. When it comes to high speed machining, our machine not only features maximum cutting stability, but is combined with excellent surface finish.

# Ultra Rigid Structure

## A Guarantee of Accuracy in High Speed Machining

- » All major structural parts are manufactured from rigid cast iron to achieve an optimal stability of structure.
- » The box type column and base is a symmetrical construction combined with scientific cross ribs reinforcement. This results in greater structural rigidity while reducing thermal deformation to a minimum.
- » The machine structure is subject to Finite Element Analysis, enabling the it to exhibit an optimal rigidity and high machining accuracy.
- » Oversized column base is extremely rigid that provides a solid foundation for machining accuracy.

### Oversized, Massive Column

- » The column is a "Y" shaped symmetrical structure with outstanding balance design. The reinforced column will not deform due to forces from the right and left side. As a result, higher structural stability and superior machining accuracy can be obtained.
- » The column is fully supported across the full width of base. This is combined with cylindrical pins and adjustment blocks to achieve complete support, resulting in greater rigidity and stability.

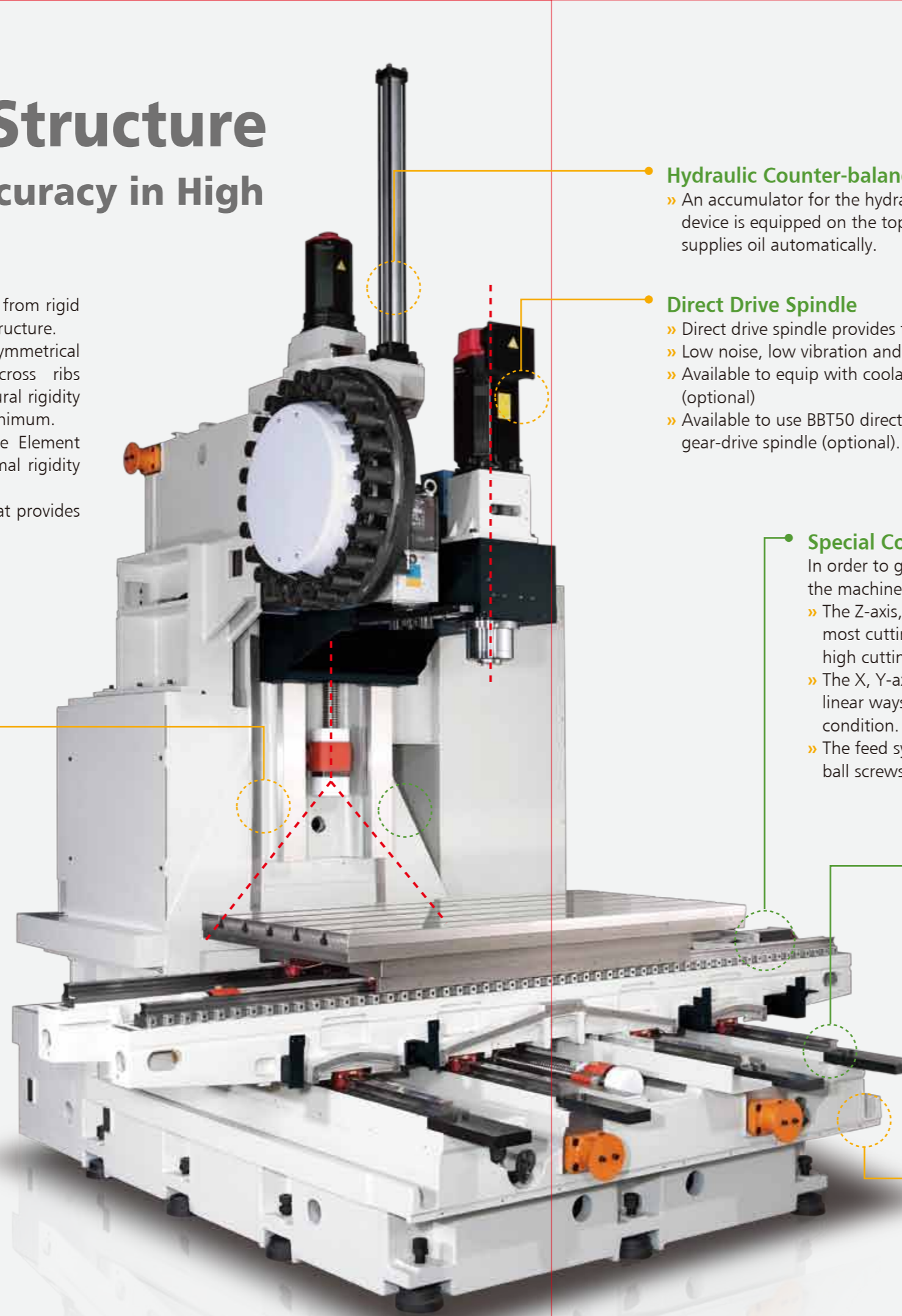

### Hydraulic Counter-balance on Z-axis

- » An accumulator for the hydraulic counter-balance device is equipped on the top of column, which supplies oil automatically.

### Direct Drive Spindle

- » Direct drive spindle provides the best cutting performance.
- » Low noise, low vibration and low thermal growth.
- » Available to equip with coolant through spindle device (optional)
- » Available to use BBT50 direct-drive spindle or BBT50 gear-drive spindle (optional).

### Special Complex Slideway Design

- In order to get an even balance between cutting rigidity and axis moving efficiency, the machine is designed with complex slideways.
- » The Z-axis, that bears most cutting force, is designed with box ways for absorbing most cutting vibration through its damped capability. Such design will provide high cutting efficiency and create fine finish on workpiece surface.
  - » The X, Y-axis, on which high speed machining is required, are equipped with linear ways to achieve stable and rapid traverse even under a heavy loading condition.
  - » The feed systems on three axes are a separate construction for reducing length of ball screws, while ensuring excellent rotational inertia during high speed rotation.

### Oil Fluid Separation

- » X,Y-axis are mounted with roller type linear ways.
- » With the oil fluid separation design, lubrication oil is separated from cutting fluid. This will prevent cutting fluids from deterioration that affects the machining and environment issues.
- » The separated cutting fluid is reclaimed and collected in an oil fluid separation box for reuse, the separated lubrication oil is collected in a box for waste oil disposal to meet the environmental requirement.

### Column Base

- » The extra wide column base with outstanding structural rigidity provides a solid foundation for precision machining.

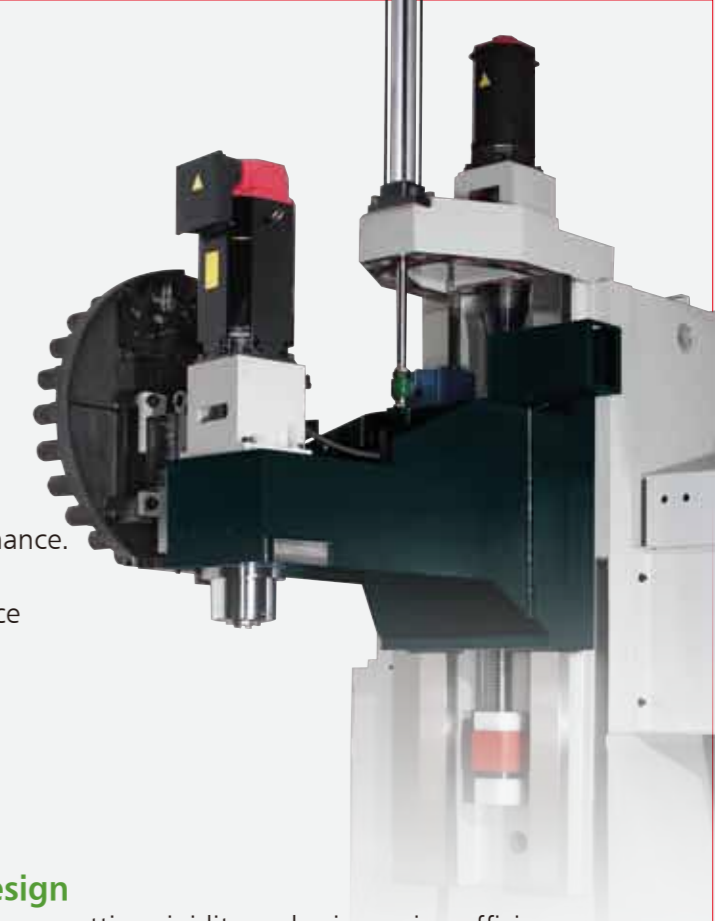

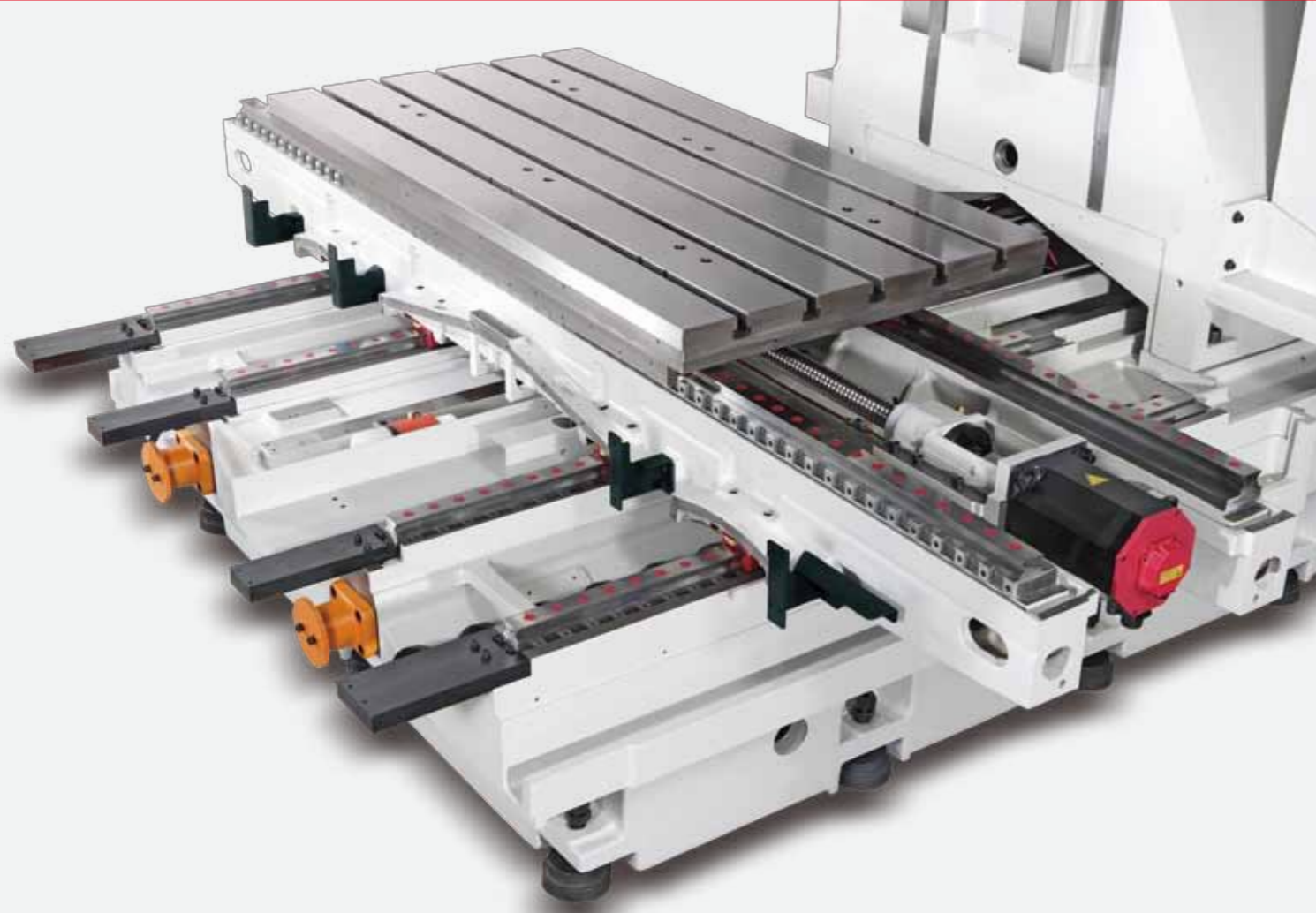

**Easy mounting of the linear guide ways ensures ease of service over the life of the machine**  
**Increased Repeatability on 3 Axes**

- » The block of linear way is fastened downward to accurate taper wedges, maintenance and adjustment.
- » The saddle is supported by 4 linear ways. When the table is moving in the X-axis, gravity will always locate in the base. This feature prevents overhang problems on the saddle and increases machining stability.

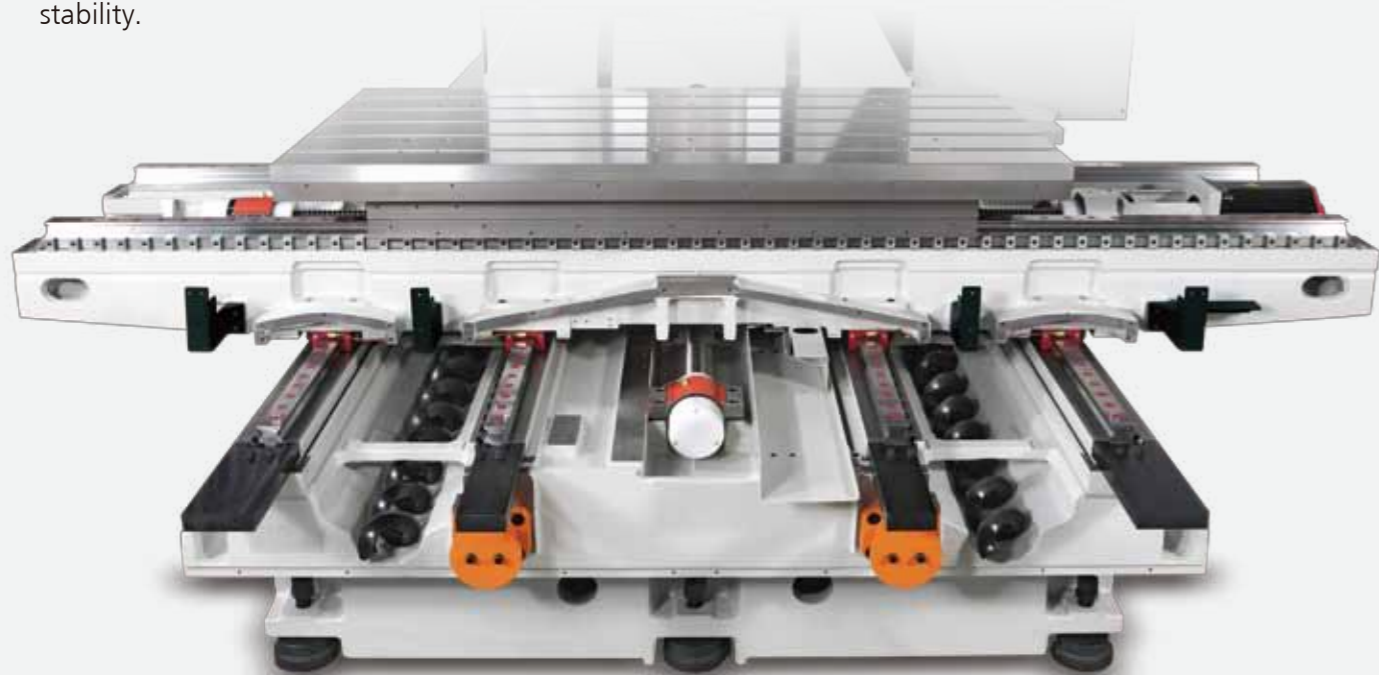

**Four Linear Ways on Base**

- » The base is mounted with four linear ways providing a good firm support.
- » Chip augers are equipped at both sides of base for quickly removing chips. With these chip augers, chip heat will be removed to effectively prevent structural deformation.

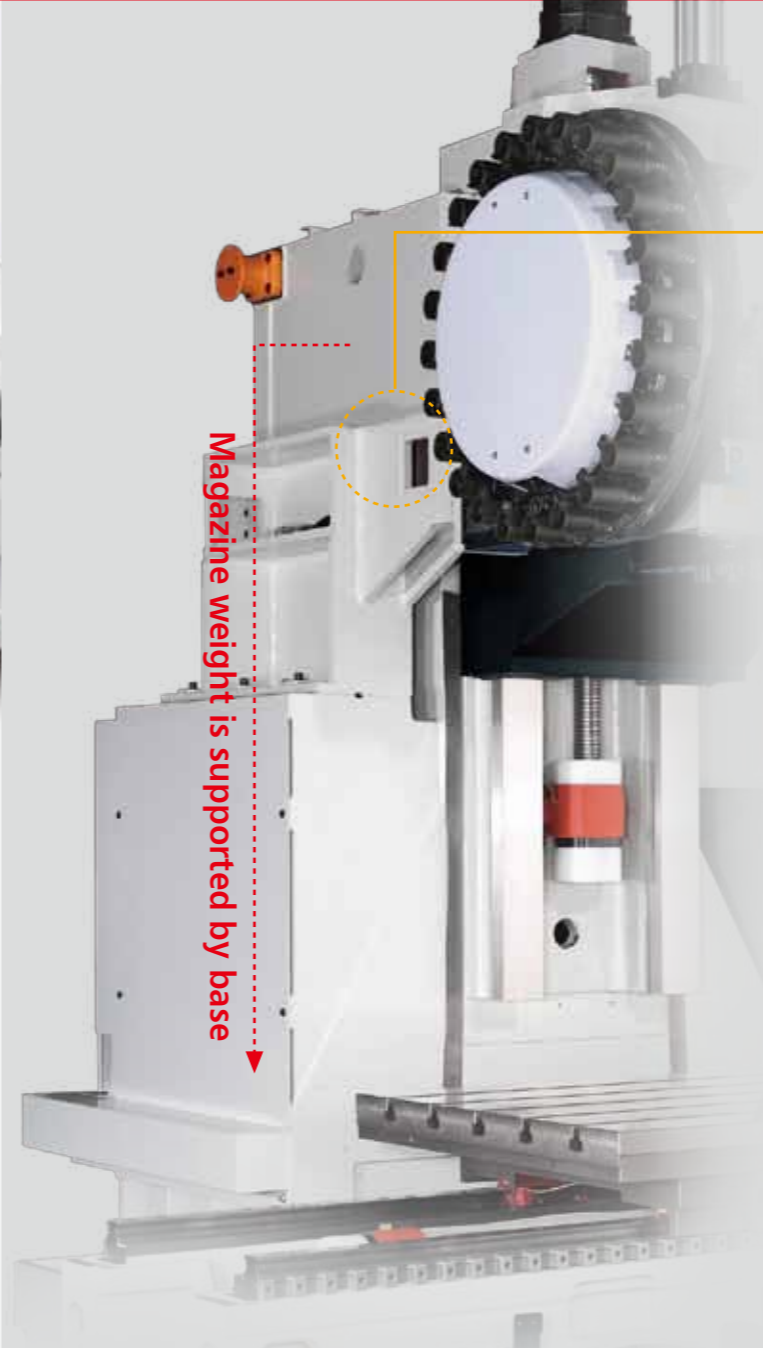

- » The magazine is supported by an additional bracket to reduce affection of the magazine weight to the column, so as to increase machining stability.

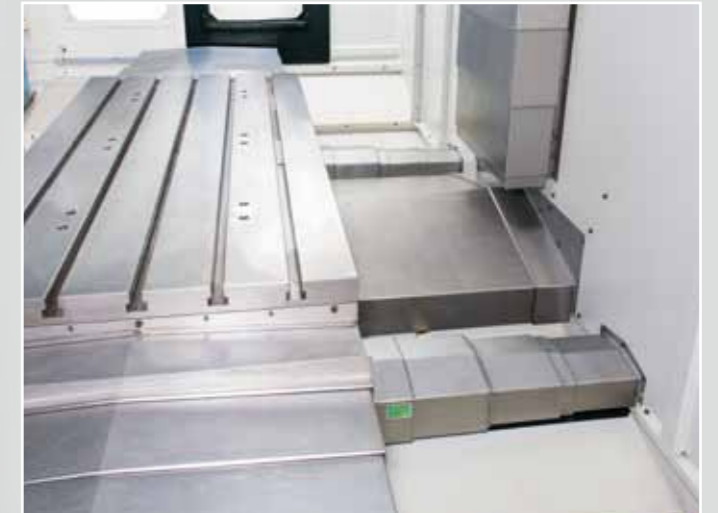

**X, Y-axis Telescopic Guards**

- » An additional telescopic guard is provided under the Z-axis for protection of Z-axis slideways.
- » The back side of the two middle linear ways on Y-axis are protected by two-piece type telescopic guard, and the front side of the two middle and two outside linear ways are protected by multi-piece telescopic guard for increasing protection effect.



**Well-planned Electrical Cabinet**

- » The centralized electrical cabinet saves wiring time and permits ease maintenance.
- » The electrical cabinet is equipped with a heat exchanger to ensure constant temperature in the electrical cabinet. It also provides protection for electronic components, control and motor driver.



**Convenient Air, Hydraulic And Lubrication System Maintenance**

- » The air, hydraulic and lubrication systems are centralized at the back side of the machine for convenient maintenance and inspection.

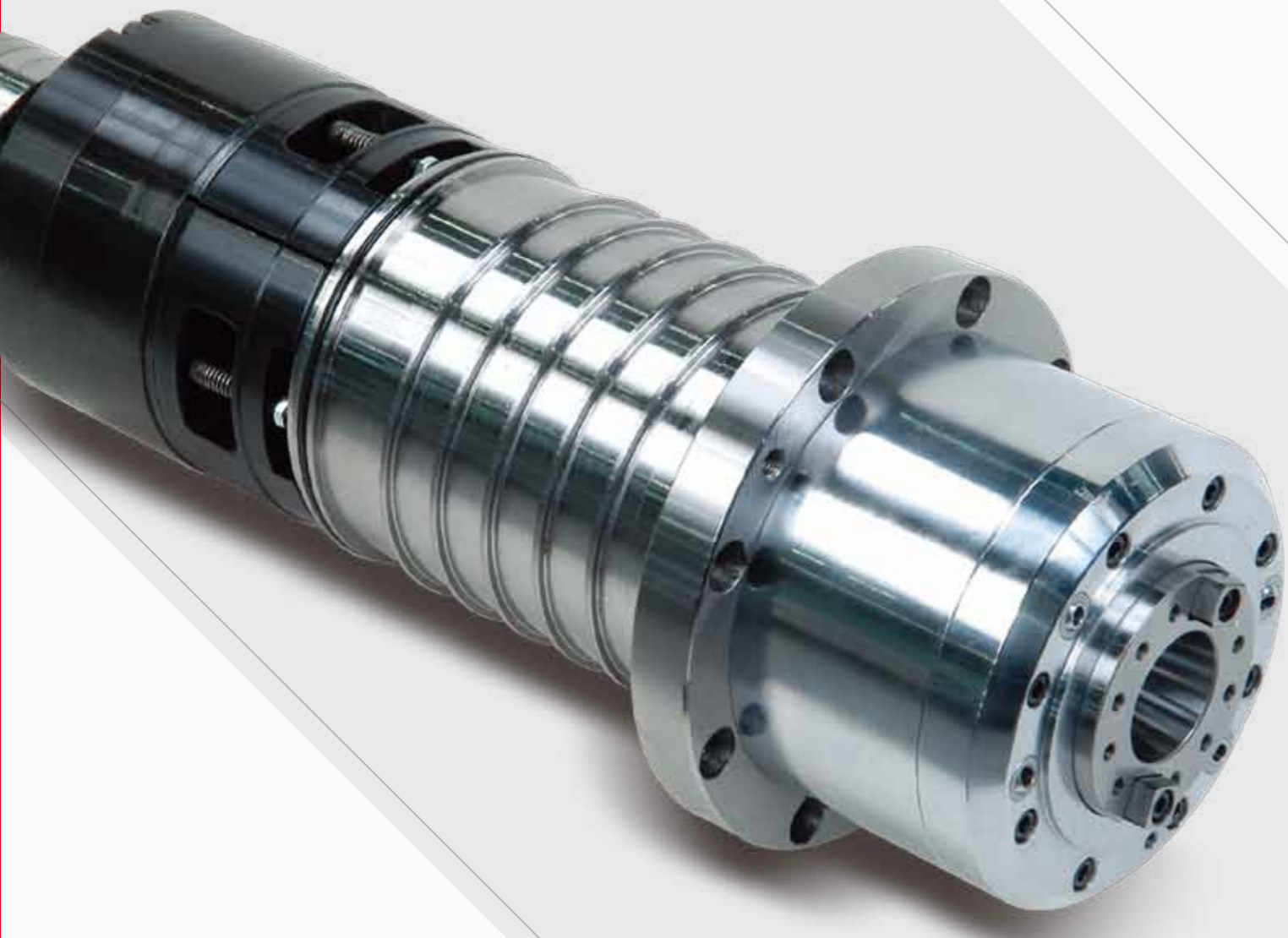

# High Speed / High Precision Machining

## Advanced design concepts that enhances speed and efficiency

BBT40-15,000RPM DIRECT DRIVE SPINDLE (OPTIONAL)

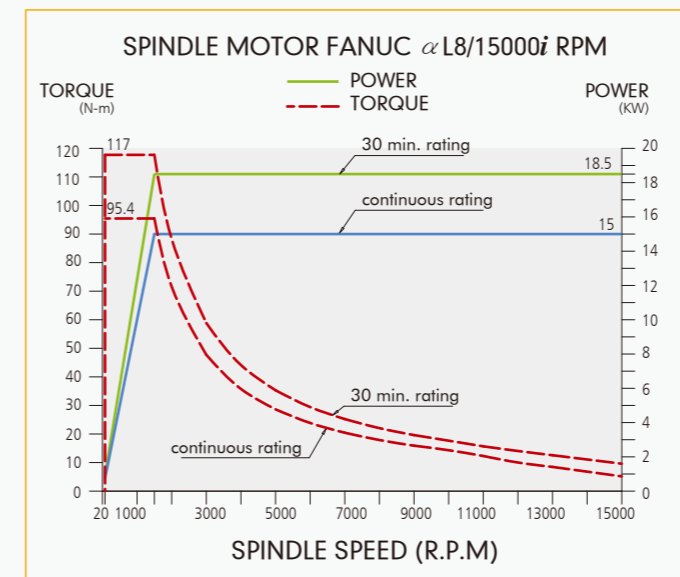

BBT50-10,000 RPM DIRECT DRIVE SPINDLE (OPTIONAL)

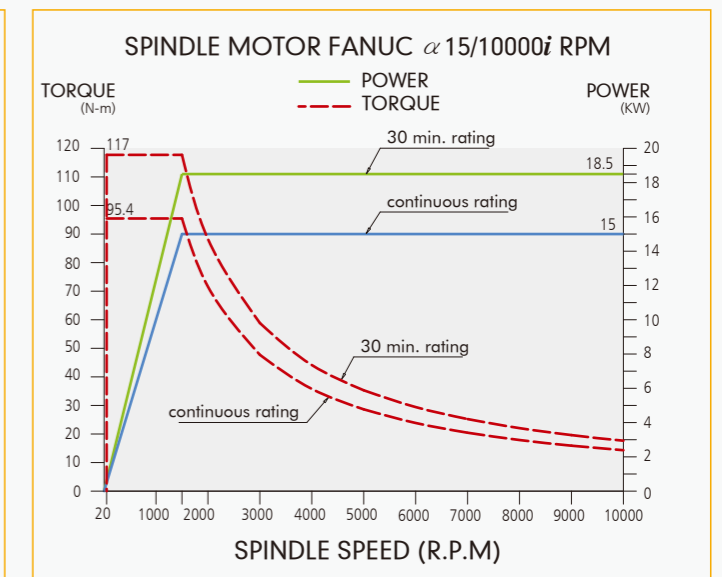

## All New MCV-1680

Equipped with direct drive spindle to take full advantage of its ultimate machining accuracy.

»Low Cost »Low Vibration »Low Noise »Easy to Install »Easy to Maintain »High Rigidity »High Precision



### BENEFITS OF DIRECT DRIVE SPINDLE

#### Low Cost

» The high speed direct drive spindle has lower cost than that of a built-in type spindle.

#### Low Vibration & Low Noise

» The direct spindle is not affected by a side force that usually occurs on a belt drive spindle, therefore it helps to reduce vibration, noise and tool wear.

#### Convenient to Install and Maintain

» The direct drive spindle is easy to install. As the spindle and the motor is separated, its maintenance cost is lower than that of a built-in type spindle.

#### High Rigidity

» The inside diameter of spindle bearing is  $\varnothing 70$ mm, featuring high rigidity to resist heavy cutting.

#### High Precision

» The temperature growth and motor heat of the direct-drive spindle have less affection in spindle head displacement than a belt-drive spindle or built-in type spindle, as such it can provide more stable machining accuracy.



# SPECIFICATIONS, ACCESSORIES AND DIMENSIONS

## SPECIFICATIONS

MODEL	UNIT	MCV-1680
<b>TABLE</b>		
Table surface	mm (inch)	1800 x 850 mm
T-slots (w x no. x pitch)	mm (inch)	22 x 5 x 150 mm
Max. table load	kg (lbs)	2500 kgw
<b>TRAVEL</b>		
X-axis travel	mm (inch)	1680 mm
Y-axis travel	mm (inch)	850 mm
Z-axis travel	mm (inch)	800 mm
Distance from spindle nose to table surface	mm (inch)	200~1000 mm
Distance from spindle center to column surface	mm (inch)	930 mm
<b>SPINDLE</b>		
Spindle nose taper		N.T.40
Spindle speed	R.P.M.	12,000 r.p.m
Spindle speed range		Infinite variable
<b>FEED</b>		
X, Y, Z-axis cutting feed rates	mm/min (inch/min)	1~15000 mm/min
X, Y, Z-axis rapid traverse	m/min (inch/min)	36 / 36 / 20 m/min
Minimum input increment	mm (inch)	0.001 mm
<b>ATC (Automatic Tool Changer)</b>		
Tool storage capacity	Tools	24 tools
Tool shank type		BBT40
Max. tool dia. x length	Ø x mm (inch)	Ø90 x 300 mm
Max. tool weight	kg (lbs)	7kgw
Max. tool dia. (without adjacent tool)		180 mm
Tool selection		Random
<b>MOTORS</b>		
Spindle drive (30 min./cont.)	Kw (HP)	11 kw (14.7HP) / 7.5 kw (10HP)
X-axis servo motor	Kw (HP)	4.0 Kw (5.4HP)
Y-axis servo motor	Kw (HP)	4.0 Kw (5.4HP)
Z-axis servo motor		7.0 Kw (9.3HP)
<b>INSTALLATION REQUIREMENT</b>		
Space occupied	mm (inch)	4493 x 4857 mm
Machine weight	Kg (lbs)	15500 kg

Specifications are subject to change without prior notice.

## » STANDARD

- Heat exchanger
- Removable manual pulse generator
- Fully enclosed splash guard
- RS-232 interface
- Automatic power off
- Call light
- Automatic lubrication equipment
- Work light
- Tool box and tool kits
- Spare fuses
- Pendant type operator panel
- Spindle cooler
- Rigid tapping
- Chip augers on base x 2 sets
- 24-tool cam type tool changer

## » OPTIONS

- Chip augers on base x 4 sets
- Screw type chip conveyor & chip bins
- Flat type chip conveyor & chip bins
- 4th axis connector
- Coolant through spindle device (15/30/50/70 bar)
- Coolant wash
- Automatic tool length measuring device
- Automatic centering device
- Cam type ATC (BT40-30/48 tools optional) (BT50-30/40 tools optional)
- Direct-drive spindle BBT40-10,000/15,000 rpm
- Direct-drive spindle BBT50-10,000 rpm
- Gear-drive spindle BT50-6,000 rpm

## MACHINE DIMENSIONS

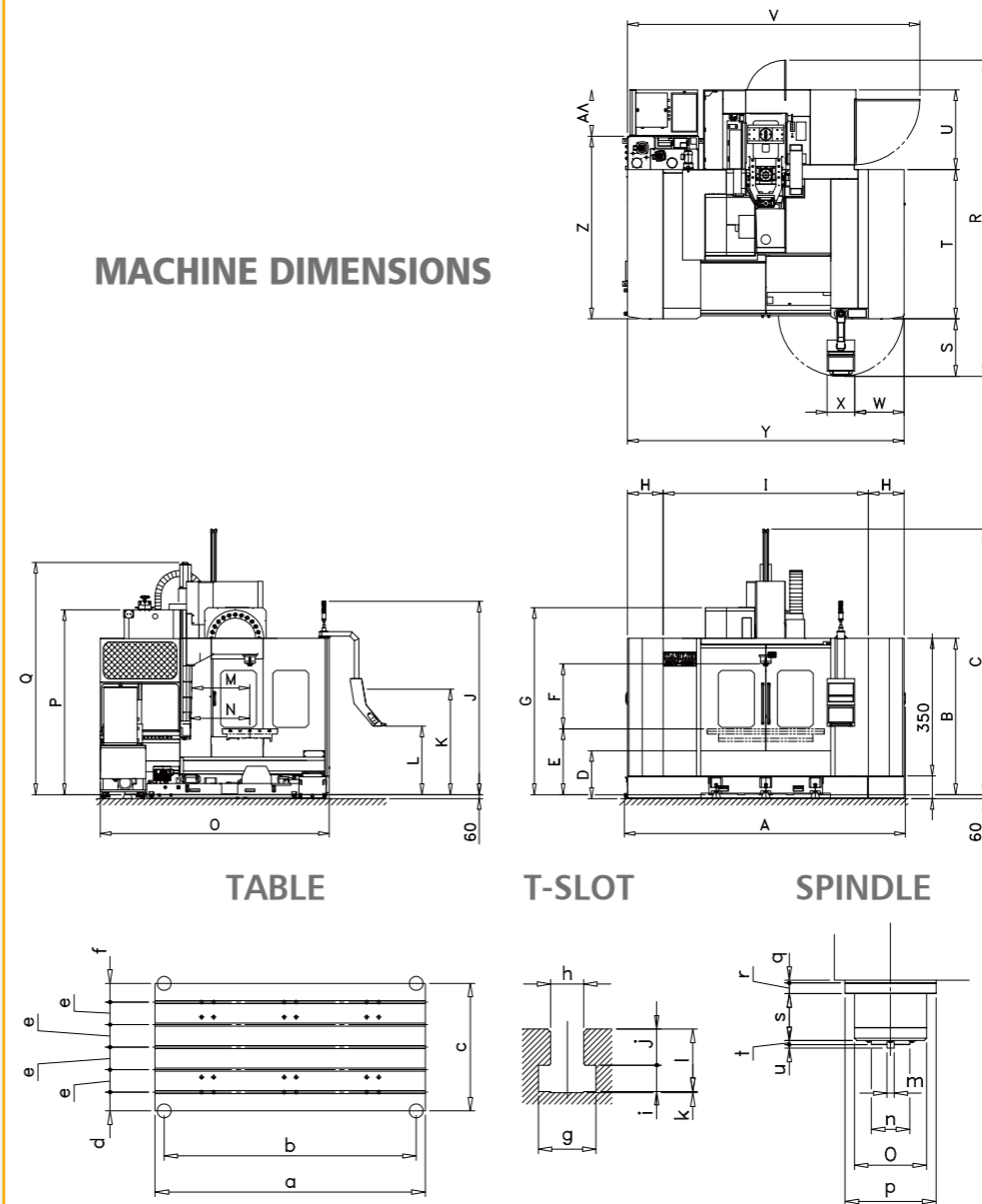

## SPINDLE POWER / TORQUE DIAGRAM DIRECT DRIVE SPINDLE 12000 RPM

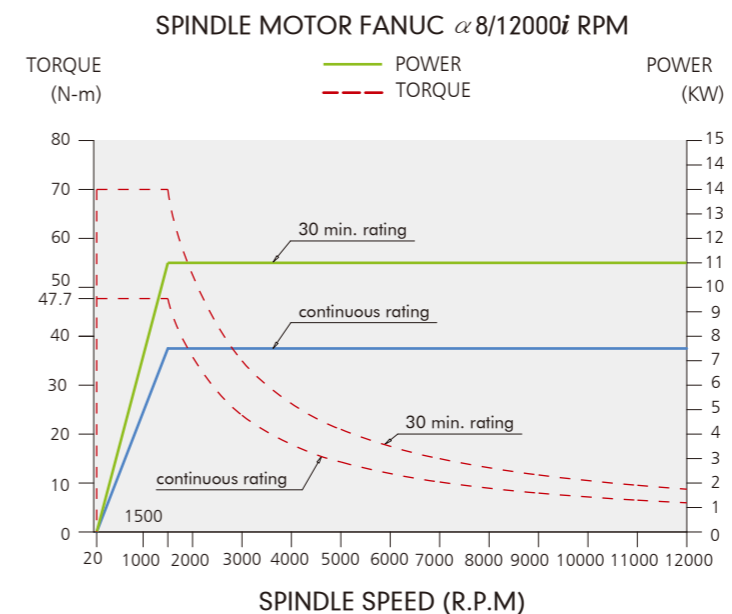

## EXTERNAL DIMENSIONS

Model	MCV-1680	
Unit	mm	inch
A	4320	170.08
B	2400	94.49
C	4076	160.47
D	735	28.94
E	1010	39.76
F	200-1000	7.87-39.37
G	2872	113.07
H	550	21.65
I	3150	124.02
J	2972	117.01
K	1620	63.78
L	1053	41.46
M	890	35.04
N	930-1355	36.61-53.35
O	3520	138.58
P	2840	111.81
Q	3566	140.39
R	4857	191.22
S	882	34.72
T	2295	90.35
U	1225	48.23
V	4493	176.89
W	575	22.64
X	426	16.77
Y	4250	167.32
Z	2807	110.51
AA	713	28.07

## TABLE & T-SLOT

Model	MCV-1680	
Unit	mm	inch
a	1800	70.87
b	1680	66.14
c	850	33.46
d	125	4.92
e	150	5.91
f	125	4.92
g	38.5	1.24
h	22	0.87
i	17.5	0.69
j	24	0.95
k	1	0.04
l	41.5	1.63
m	15.9	0.63
n	85	3.35
o	160	6.30
p	202	7.95
q	6	0.24
r	24	0.95
s	104	4.09
t	9	0.35
u	8	0.31

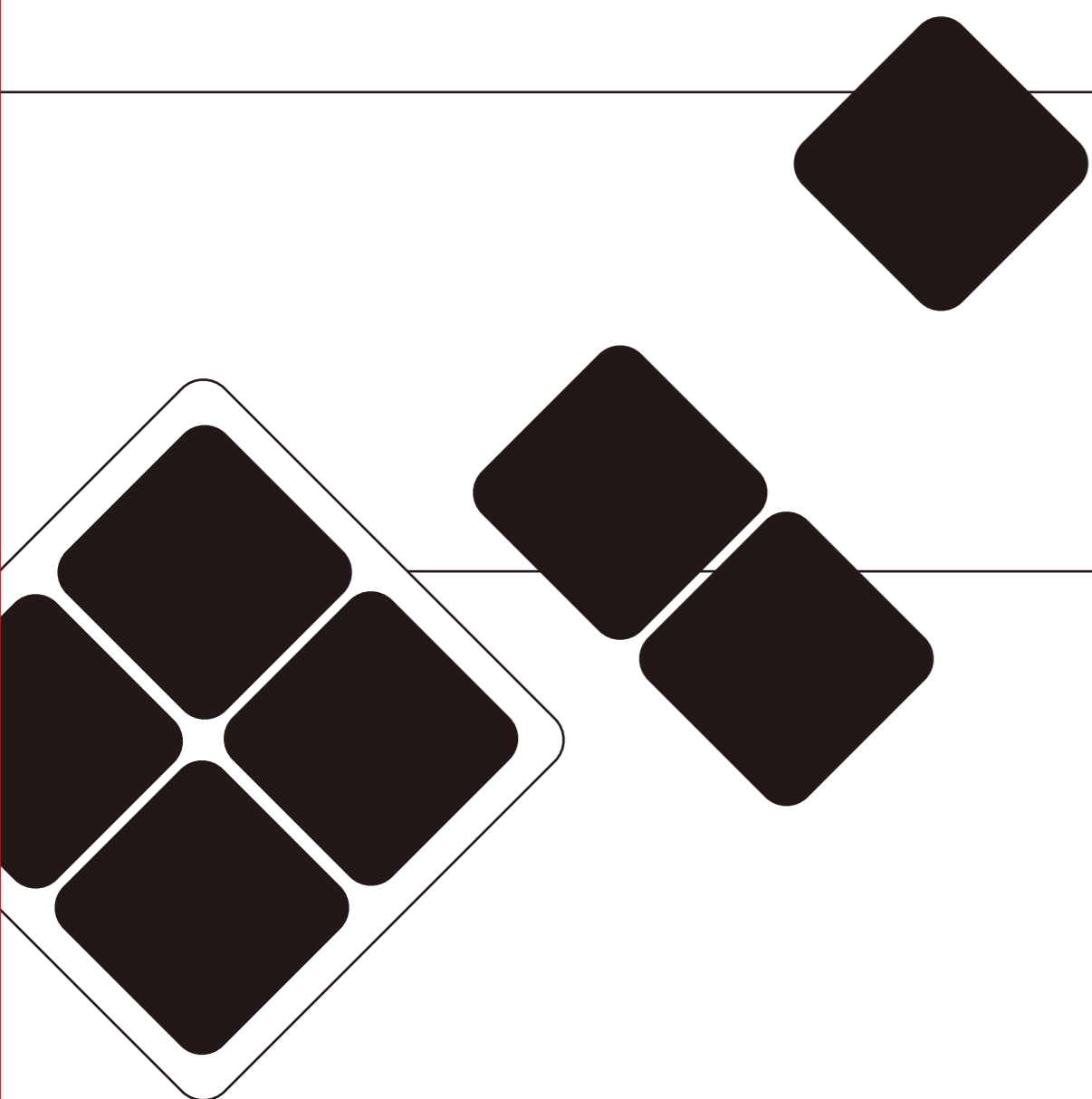

MCH-630

MCV-720

MCV-1020A

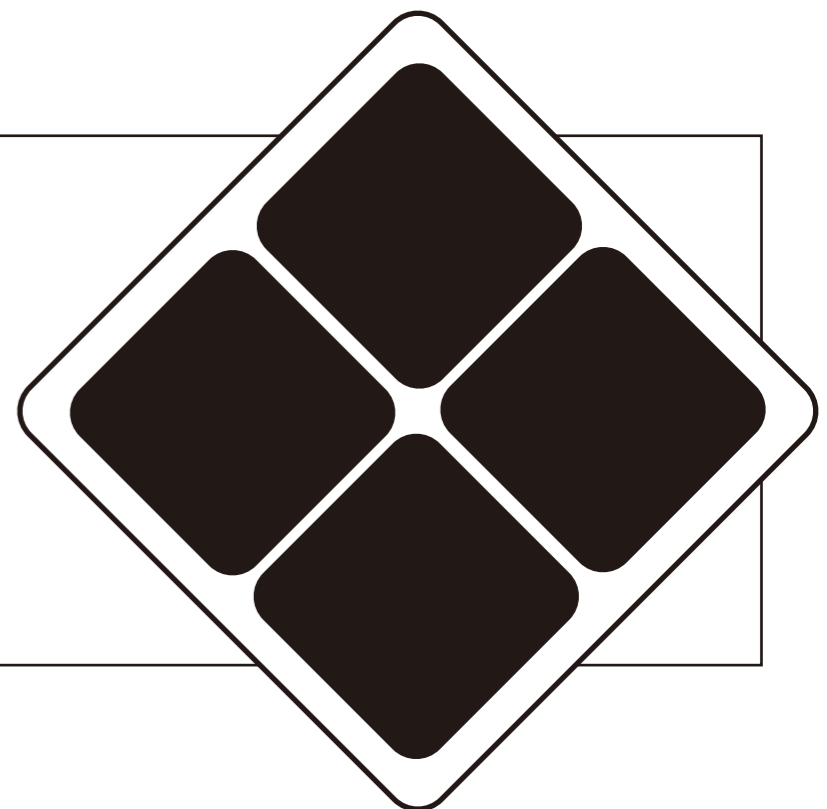

MCV-1020BA

MCV-1200

MCV-1250

MCV-1450

MCV-1700

MCV-2100

MCV-2600

DCM-2213



**DAH LIH MACHINERY INDUSTRY CO., LTD.**

The Latest and Best Quality Machinery.  
**DAHLIH**<sup>®</sup>