

MCH-630

MCV-720

VERTICAL MACHINING CENTER

MCV-1020A

MCV-1060

MCV-1020BA

MCV-1200

MCV-1250

MCV-1450

MCV-1700

MCV-2100

MCV-2600

DCM-2213



DAH LIH MACHINERY INDUSTRY CO., LTD.

No. 3, Kung-Yeh Lane, Fengcheng Road, Nanshih Village,

Wufeng District, Taichung City, 41357, Taiwan.

TEL:886-4-23334567 FAX:886-4-23307567

E-mail:export.sale@dahliah.com.tw Http://www.dahliah.com.tw



022-D2-00-023

1000.12.2015

The Latest and Best Quality Machinery.
DAHLIH®

MCV-1060

VERTICAL MACHINING CENTER

Quality and Efficiency

The Perfect Solution from Dah Lih

- » Built with Dah Lih's tradition of high reputation and fine craftsmanship.
- » The major casting parts are designed and analyzed by advanced "Finite Element Analysis" for optimum structural rigidity and accuracy.
- » The entire machine is ruggedly constructed throughout for lifetime accuracy and rigidity.
- » Coolant jets around the spindle nose provide excellent cooling effect for the cutting tool and workpiece.
- » The machine can fit into a standard container. Even with a compact construction, the machine offers great machining capacity and variable functions to help customers to upgrade to a competitive edge.
- » High rigidity, high precision, minimum vibration, minimum noise. Easy to install and maintain.

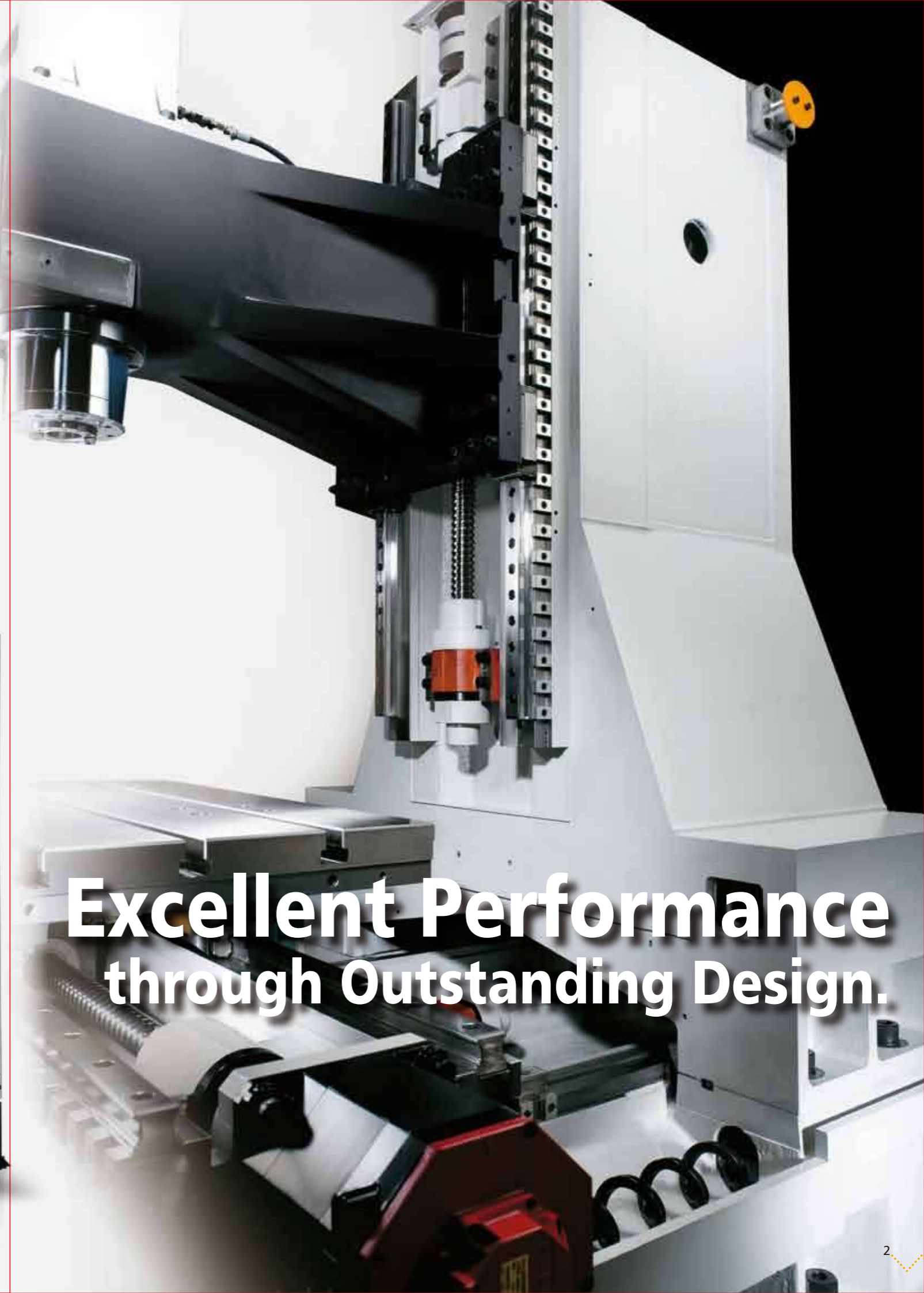

**Excellent Performance
through Outstanding Design.**

High Speed, High Precision Machining

Designed using advanced concepts that provide unrivalled machining efficiency.

The Best Choice for Precision Machining

- » Automotive and Motorcycle industry
- » Precision parts machining
- » General machining
- » Mold and dies

Optimal Structure Design Stable...Rigid...Precise....

- » Extra wide column base combined with rigid structure to provide a solid foundation for precision machining.
- » All major castings are analyzed through "Finite Element Analysis" software that ensures excellent machine rigidity and cutting accuracy.
- » All structural parts are manufactured from high quality cast iron, assuring the best possible stability of the structure.
- » The box type column and base is a symmetrical construction combined with scientific cross ribs reinforcement. This results in greater structural rigidity while reducing thermal deformation to a minimum.
- » The feed systems on the three axes are separate construction for reducing length of ball screw, while ensuring excellent rotational inertia during high speed rotation.
- » The three axes slide ways are mounted with ball/roller type linear ways.



Y-AXIS TELESCOPIC GUARD

An additional telescopic guard is provided at the rear side of Y-axis to increasing chip prevention on Y-axis.

CONVENIENT TABLE DISMANTLING AND MOUNTING

The table is fastened downward, making table dismantling and mounting easier. Also, convenient for maintenance and adjustment.

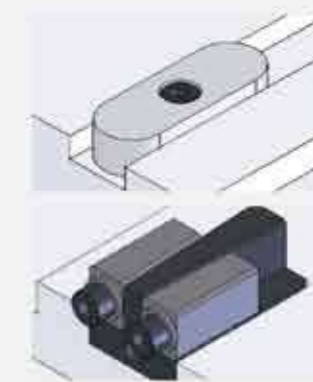

COLUMN SUPPORT

The column is fully supported across the full width of the base. This is combined with positioning keys and tapered gibs to achieve complete support, resulting in greater rigidity.

LARGE Y-AXIS SPAN

» Extra large span between Y-axis slideways always keeps gravity located in the base when the table travels in X-axis. This feature prevents overhang problem on saddle and hence increases machining stability.

MASSIVE COLUMN

The column is a reversed "Y" shape symmetrical construction with superior balance design, representing high machining accuracy.



LINEAR GUIDEWAY

Dah UH have developed a new linear guideway clamping method, this provides for better clamping force, rigidity and location. This new design allows for much easier field services for either replacement or adjustment.

CHIP AUGERS

» Chip augers are equipped at both sides of base for quickly removing chips. With these chip augers, chip heat will be removed to effectively prevent thermal deformation of the structure.

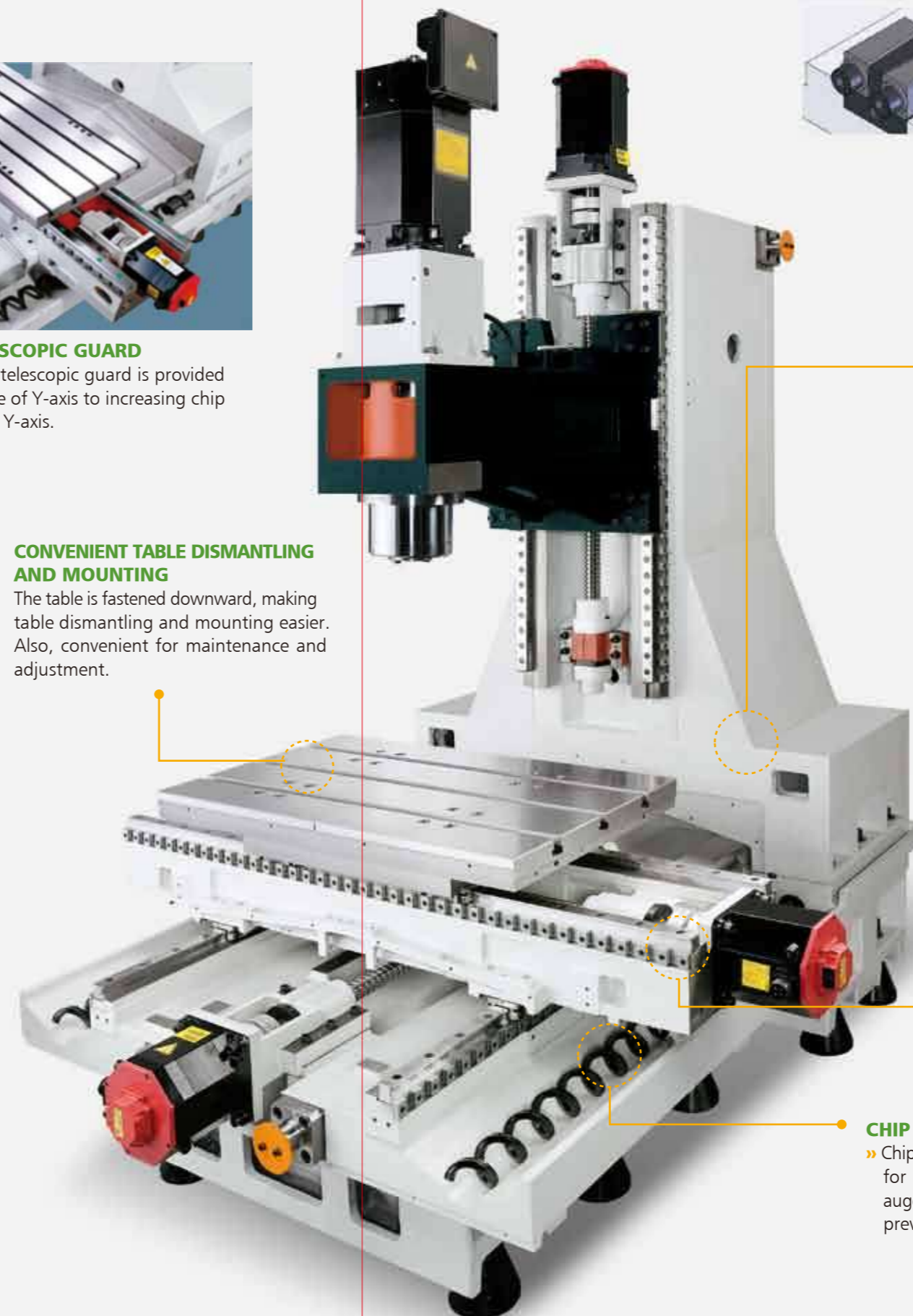

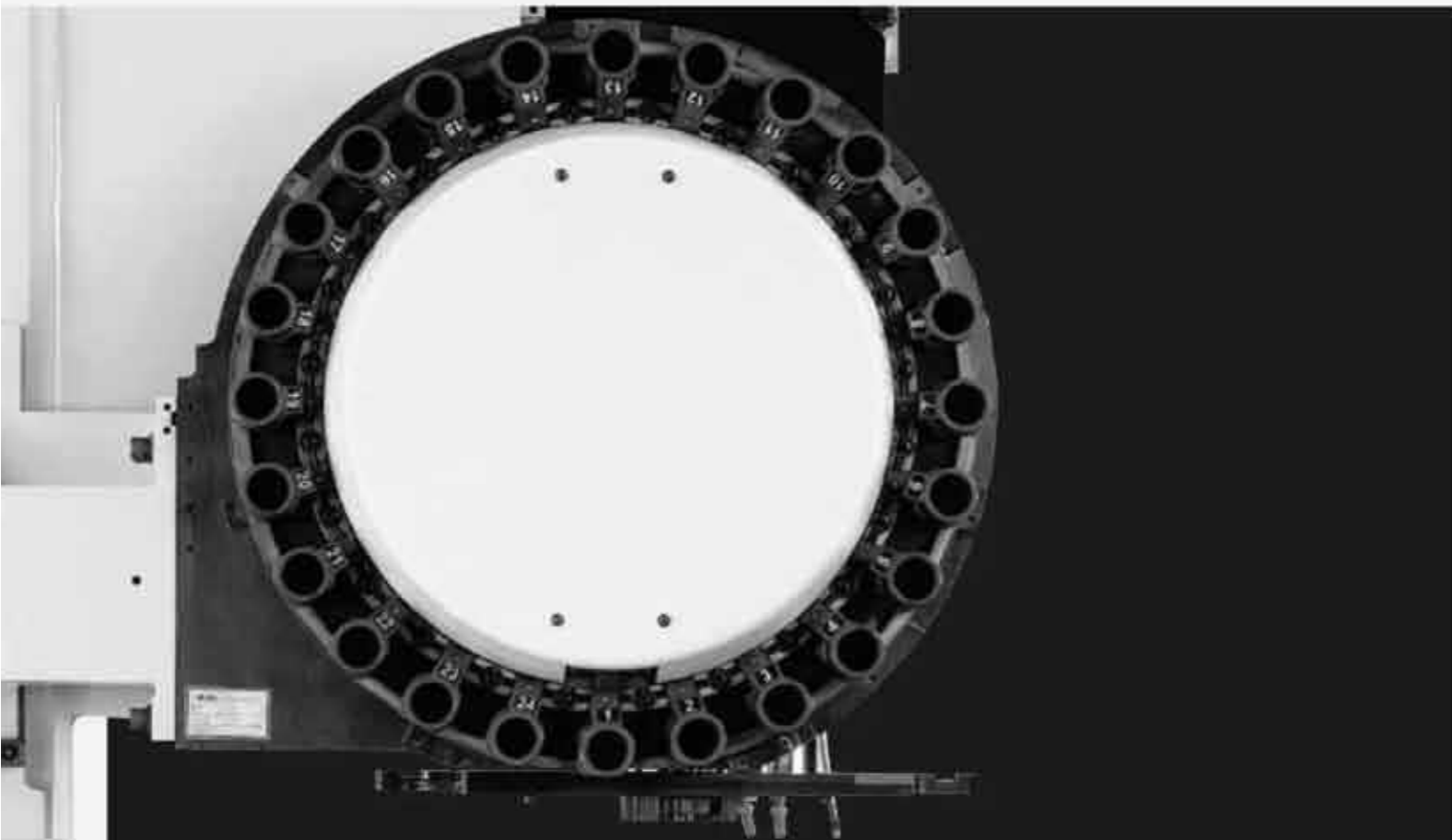

24 Tools CAM TYPE MAGAZINE

The cam type magazine rotation is driven by a cylindrical cam for fast and dependable tool change. Tool loading capacity is 24 tools. Random tool selection provides efficient tool changing.

- Cam Mechanism ATC (24 Tools)

Max. Tool Dia. x Length	Ø x mm Ø x inch	Ø90 x 300 Ø3.54 x 11.81
Max. Tool Weight	kg lbs	7 15
Max. Tool Dia. of Adjacent Pots are Empty	Ømm	Ø150

- 10,000/12,000/15,000 rpm direct-drive spindle.



High Speed and High Precision Machining

Advanced Design Concepts that Enhance Speed and Efficiency.

Equipped with advanced control for ultra high machining accuracy.

High Speed / High Precision

- » ACC / DECC speed control
- » High precision contour control
- » Quadrant change offset
- » Data server
- » Vibration dampening
- » Nurbs interpolation
- » Extremely rigid structure
- » High torque servo drive system
- » High speed spindle



15,000 RPM Direct Drive Spindle (Optional)

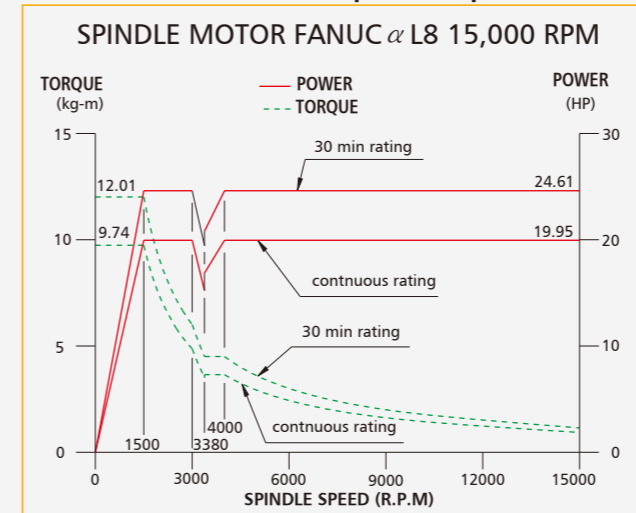

15,000 RPM Built-in Type Spindle (Optional)

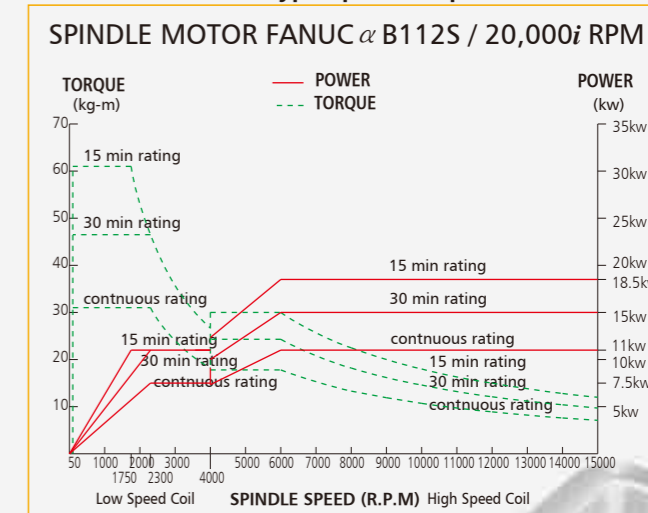



Latest Advanced CNC Controller

This machine is available to equip with Fanuc, Heidenhain or other brands of CNC Controllers.

SPINDLE COOLER
It provides cooling to the spindle and ball screws.

HEAT EXCHANGER FOR ELECTRICAL CABINET

The high performance heat exchanger ensures a constant temperature inside the electrical cabinet. It provides protection for electronic components, controller and motor driver.



WORK LIGHT

This Machine is equipped with water-proof work light providing lighting for the working area. The work light features soft illumination without being irritating to the operator's eyes.



CONVENIENT AIR AND LUBRICATION SYSTEM MAINTENANCE

The air/lubrication systems are centralized at the back of the machine for convenient maintenance and inspection.



WELL-PLANNED ELECTRICAL CABINET

- » The centralized electrical cabinet saves wiring time and permits convenient maintenance.
- » The electrical cabinet is equipped with a heat exchanger to ensure constant temperature in the electrical cabinet. It also provides protection for electronic components, controller and motor driver.

A Wide Range of Optional Accessories that Enable More Powerful and Efficient Operations.

» OPTIONS



AUTOMATIC TOOL LENGTH MEASURING DEVICE (DAHLI)



AUTOMATIC TOOL LENGTH MEASURING DEVICE (RENISHAW or BLUM)



AUTOMATIC WORKPIECE MEASURING DEVICE



COOLANT WASH



COOLANT THROUGH SPINDLE DEVICE



4TH AXIS CONTROL AND ROTARY TABLE



COOLANT THROUGH 3-AXES BALL SCREWS

- » This feature minimizes thermal expansion on ball screw and improves machining accuracy.

FLAT TYPE CHIP CONVEYOR

SPECIFICATIONS, ACCESSORIES AND DIMENSIONS

SPECIFICATIONS

MODEL		MCV-1060
TABLE		
Table Surface		1200 x 580 mm
T-slots (w x no.x pitch)		18 x 3 x 150 mm
Max. table load		1000 kg
TRAVEL		
X,Y,Z-axis travel		1060 mm / 560 mm / 550 mm
Distance from spindle nose to table surface		150~700 mm
Distance from spindle center to column surface		600 mm
Ball screw cooling		Without
Slideway type (X,Y,Z-axis)		Linear guideways
FEED		
Rapid traverse rate	X-axis	40 m/min
	Y-axis	40 m/min
	Z-axis	30 m/min
Cutting feed rate		10000 mm/min
Minimum feed increment		0.001 mm
SPINDLE		
Spindle type		Belt drive
Spindle motor (30 min.rating/continuous rating)		11kW (14.7HP) / 7.5kW (10HP)
Spindle nose taper		N.T.40
Spindle speed		8000 rpm
Spindle bearing size		Ø70 mm
Max. spindle torque		47.7N-m
Cooling / Lubrication method		Oil cooling / Grease
A.T.C		
Tool magazine capacity		24T
Tool shank		BBT40
Pull stud		Jaw type 45 degree pull head
Max. tool weight		7 kg
Max. tool length		300 mm
Max. tool diameter (without adjacent tool)		Ø90 (150) mm
Tool selection		Random
MOTORS		
X-axis servo motor		3kW (4HP)
Y-axis servo motor		3kW (4HP)
Z-axis servo motor		4kW (5.3HP)
OTHER		
Power required		36KVA
Air pressure required (air supply)		6 kg/cm ²
Coolant pump		3/4HP
Coolant tank capacity		300L
Machine Weight		6000kgf
Floor space occupied		2900 x 3895 mm

Specifications are subject to change without prior notice.

» STANDARD

- Heat Exchanger
- Removable manual pulse generator
- Fully enclosed splash guard
- RS-232 interface
- Automatic power off
- Call light
- Automatic lubrication equipment
- Work Light
- Tool box and tool kits
- Spare fuses
- Swing type operation panel
- Spindle oil cooler
- 24 tools can type ATC
- Rigid tapping
- Chip augers on base

» OPTIONS

- Screw type chip conveyor with chip bins
- Flat type chip conveyor with chip bins
- 4th axis control
- Coolant through spindle device with filter
- Bed coolant wash
- Automatic tool length measuring device
- Automatic workpiece measuring device
- Linear scale
- 30, 32, 40 tools can type ATC
- 12,000 rpm/15,000 rpm direct drive spindle
- 15,000 rpm built-in type spindle

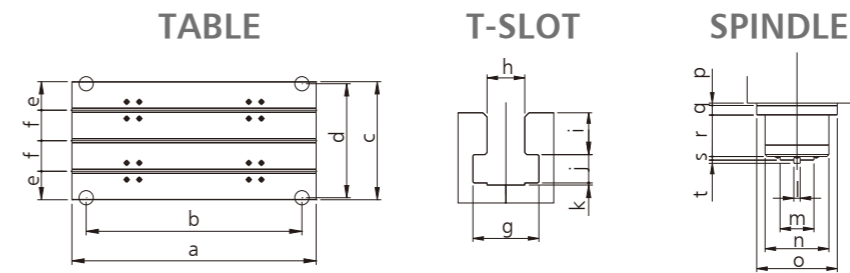
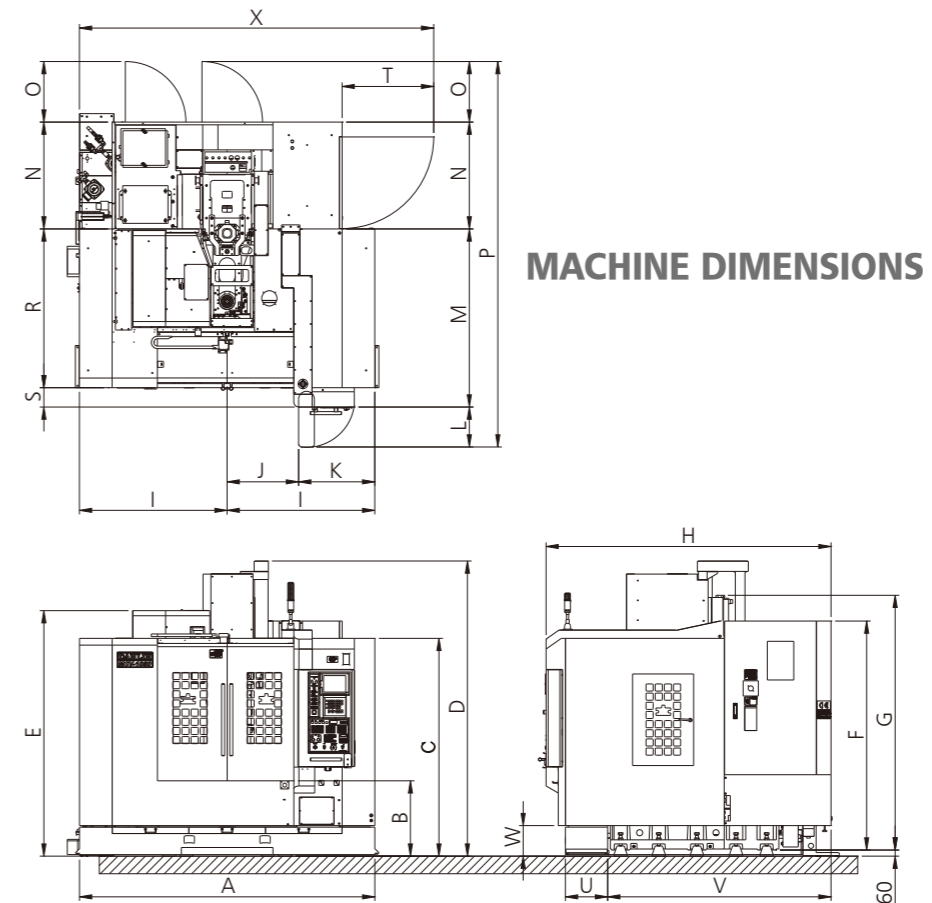

SPINDLE POWER / TORQUE DIAGRAM

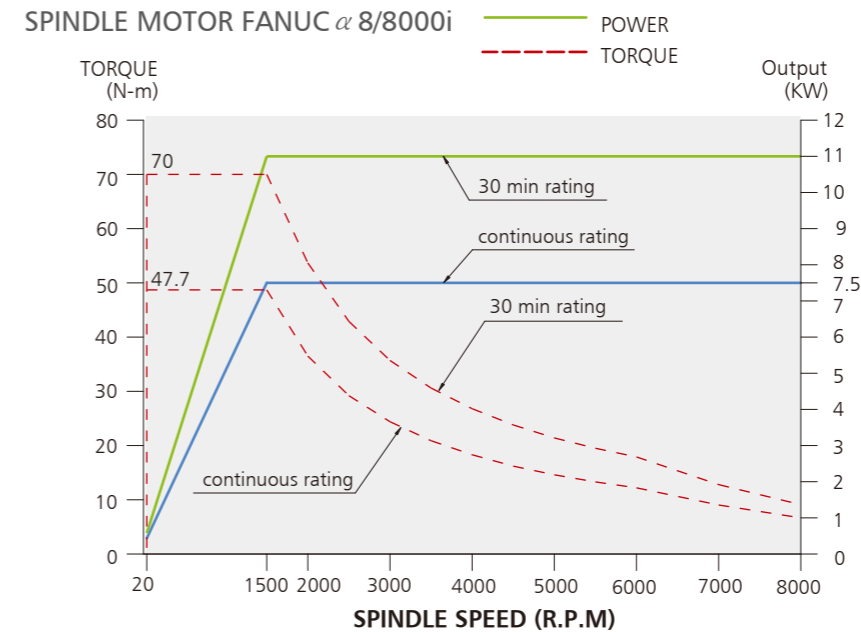

EXTERNAL DIMENSIONS

Model	MCV-1060	
Unit	mm	inch
A	2900	114.17
B	740	29.13
C	2140	84.25
D	2900	114.17
E	2410	94.88
F	2250	88.58
G	2503	98.54
H	2800	110.24
I	1450	57.09
J	702.5	27.66
K	748.5	29.47
L	392.5	15.45
M	1750	68.90
N	1050	41.34
O	595	23.43
P	3895	153.35
R	1560	61.42
S	190	7.48
T	900	35.43
U	415	16.34
V	2195	86.42
W	300	11.81
X	3480	137.01

TABLE & T-SLOT

Model	MCV-1060	
Unit	mm	inch
a	1200	47.24
b	1060	41.73
c	580	22.83
d	560	22.05
e	140	5.51
f	150	5.91
g	31.5	1.24
h	18	0.71
i	20	0.79
j	13.5	0.53
k	1	0.04
l	15.9	0.63
m	85	3.35
n	160	6.30
o	202	7.95
p	5	0.20
q	24	0.94
r	104	4.09
s	9	0.35
t	8	0.31